

CATALOG

ABB micro drives

ACS255, 0.25 to 20 hp / 0.37 to 15 kW



Select and order your drive

Type designation is a unique reference number that clearly identifies the drive by construction, power and voltage rating and selected options. Using the type designation you can specify your drives from the wide range of options available. Options are added to the type designation using the corresponding "plus" (+) code.

Build up your own ordering code using the type designation key below or contact your local ABB drives sales office and let them know what you want.

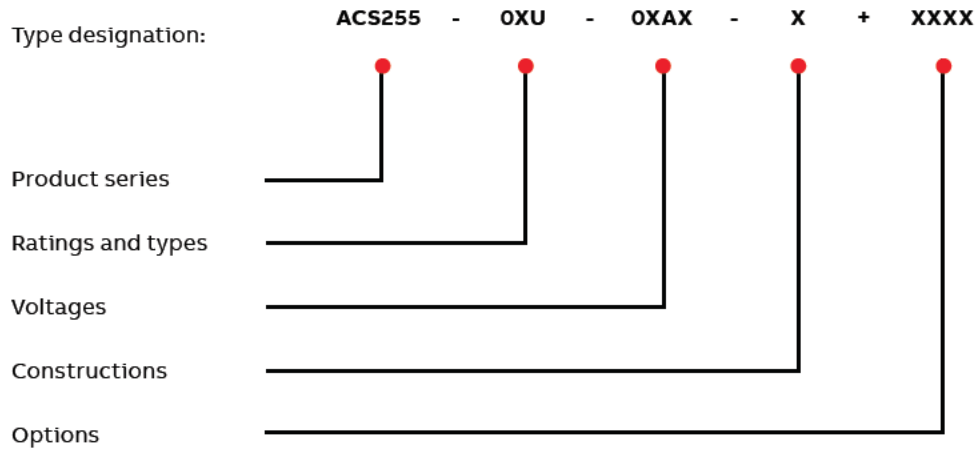

Table of contents

04-05	ACS255 Introduction
07-10	ACS255-IP20 Main features Overview Data sheet Ratings and types Dimensions and weights
11-14	ACS255-IP66 Overview Data sheet Ratings and types Dimensions and weights
15-18	Technical data Cooling Fuses and cable sizes Control connections (115, 240, 480 V) Control connections (600 V)
19	Options
20-28	Braking resistors Single-phase Three-phase Resistor technical data CR case resistor GCE resistor Installation instructions
29-35	Reactors Input reactors Output filters
36-37	Life cycle management

ACS255 micro drive

Introduction

ACS255 IP20



ACS255 IP66 - NEMA 4X



Main attributes

Feed-thru wiring, embedded Modbus-RTU, built-in macros for simple machine interface

Wide range of input voltages, high protection class enclosure for harsh environments, Modbus-RTU as standard

HP range

1~115 V - 0.5 to 1.5 HP
3~600 V - 1 - 20 HP

1~115 V - 0.5 to 1.5 HP
1~230 V - 0.5 to 5 HP
3~230 V - 0.5 to 5 HP
3~460 V - 0.5 to 10 HP
3~600 V - 1 to 15 HP

Voltage range

1~120 V In / 3~230 V Out
3~600 V In / Out

1~115 V In / 3~230 V Out
1~230 V In / 3~230 V Out
3~230 V In / Out
3~460 V In / Out
3~600 V In / Out

Enclosure type

UL type 0 (IP20)

UL type 4X (IP66)

Control mode

Scalar (V/Hz) variable torque and constant torque V/Hz profiles, Sensorless vector

Scalar (V/Hz) variable torque and constant torque V/Hz profiles, Sensorless vector

Motor types

AC induction
Permanent magnet AC

AC induction
Permanent magnet AC

Communications options

Embedded Modbus-RTU

Embedded Modbus-RTU

Operator interface

Integral and/or remote mount keypad

Integral and/or remote mount keypad

ACS255 micro drive

Main features

Overview

The new ACS255 drive is an enhanced version of the popular ACS250 drive series. New features include: sensorless vector control for both AC induction and PM motors, enhanced short circuit protection, and operating mode selection. New ratings have been added to fill out the product line.

All of the existing features of the ACS250 - parameters, external dimensions, mounting locations, etc. - are the same for the ACS255. An Advanced parameter menu has been added for additional functionality.

The ACS255 drive is a part of ABB's complete range of micro drives, offering a solution for every need. The IP20 drives offer 115V and 600V options to enhance other IP20 product lines. The IP66 drives have a complete input voltage range from 115 to 600V.

ACS255 variable frequency drives feature an intuitive integrated control panel with LED display. Built-in macros and only the essential parameters make commissioning straightforward. Built-in Modbus-RTU serial communication provides ready integration with control and monitoring systems.

ACS255 micro drives are compact and offer flexible mounting options without the need for accessory mounting kits. Rapid programming and commissioning are possible using the on board setup macros. The copy stick tool can be used to transfer parameter sets between drives.

The ACS255 drive is ideal for panel builders and OEM's needing a micro drive with low cost, flexible mounting options, and rapid parameter setup.

Highlights

- Power range: 0.5 to 20 Hp, 1 & 3 phase input
- 150% peak overload capacity
- Modbus-RTU built-in
- User-friendly control panel with LED display
- Wall or DIN rail mounting options for IP20 drives
- Feed thru wiring on IP20 drives
- PI control
- Built-in brake chopper (Sizes 2 & 3)
- Sensorless vector and V/Hz control - all voltages
- Safe Torque Off (STO) (600V drives only)
- Conformally coated boards
- Operating mode selection
- Easy access to power and I/O connections for rapid installation
- Selection options for braking resistors, input reactors, & output filters

Applications

- Conveyors
- Mixers
- Material handling
- Fans and pumps
- Automated Gate Control
- Food and Beverage
- Printing
- Woodworking Machinery

ACS255 micro drive

Main features

Feature	Advantage	Benefit
Simple interface	Integrated keypad and display is easy to learn and makes commissioning straightforward ABB common programming parameter structure	Time and labor cost savings with rapid setup and commissioning
Drive & network connectivity	RS485 serial interface with embedded Modbus RTU for real time control (or monitoring) RJ45 connection port can be used with: Optional Y-splitter for daisy chain networking Remote control panel Copy Stick tool for transferring parameters between drives	Flexibility with RJ45 connectivity options Time savings with simple plug-and-play connectivity
IP66 Construction with Optional Controls	Optional operator controls: Disconnect, Fwd/Off/Rev, & Speed Potentiometer Dust and water proof design built with tough ABS plastic cover, epoxy coated heatsink that withstands high pressure washdown for food and beverage applications. Optional operator controls allows mounting directly on processing equipment located in extreme environments	Save panel building cost Less cost due to shorter motor cables with machine mounted drive Operator controls located on the machine
Full voltage range in IP66 drives	IP66 offering throughout the voltage range - 110V to 600V Global input voltage range to cover a wide range of application	Standardize on one supplier with global input voltage range save procurement and inventory cost
Feed Through Wiring & Flexible Mounting Options (IP20 Drives)	Allows for easy replacement of motor starters or soft starters in existing panels with power wires in at the top and motor cables out at the bottom Flexible mounting options - wall or DIN rail	Saves time and material cost for panel builders
600V Ratings in IP20 and IP66 Enclosures	600V capacity in a micro drive with Safe Torque Off (SIL2)	Panel design standardization with compact micro drive sizing in a 600V drive - similar to 115, 230, & 460Vmicro drives

ACS255 IP20 micro drive

Overview

Replacing a motor starter or soft starter with a drive can help your customer improve their overall energy efficiency, reduce mechanical stresses and enhance their process control. With its feed-thru wiring, the ACS255 can easily replace motor starters for general purpose low power applications, such as; augers, mixers, pumps, fans and conveyors. The key features include a integrated keypad for easy configuration, precise process control with an enhanced V/Hz control with variable torque and constant torque V/Hz profiles, sensorless vector control and embedded, Modbus-RTU communication interface for real time control and monitoring.

Main features

- Integrated display and keypad
- Feed-thru wiring
- 50°C no de-rate / 60°C max.
- Built-in macros and only the essential parameters make commissioning straightforward
- Enhanced V/Hz control (all models)
- Open loop vector - speed & torque control - for AC Induction and permanent magnet motors
- Operating Mode Select quickly configures current limit, torque characteristic and spin start parameters for Industrial, Pump, or Fan applications
- Adjustable current limit
- Power loss ride-through
- DC injection braking
- DC magnetizing start (provides maximum starting torque)
- Internal braking chopper (except frame E1)
- Modbus-RTU fieldbus as standard
- Open loop vector - speed & torque control (600 V only)
- SIL2 Safe torque-off (600 V only)
- Integrated help card

Applications

- Variable torque, constant torque or constant horsepower applications requiring a compact drive solution for cabinet mounting

Capabilities

- V /Hz and sensorless vector control with peak overload capacity of 175%
- Feed-thru wiring DIN rail mountable IP20 enclosure
- Intuitive integrated keypad
- Designed to be easy to program for simple machine interface

ACS255 IP20 micro drive

Data sheet

Performance features	Control modes	115 VAC: V/Hz and open loop vector 600 VAC: V/Hz and open loop vector
	Operator interface module	Integral drive mounted
	Display lines	6-character LED display
	Programmable preset speeds	Four
	Analog output: one	One (0-10 VDC)
	Auto restart	Yes – up to 5 attempts
	Frequency avoidance	One band
	Fault history	Last four faults
	Digital inputs: four	Two programmable digital inputs, two user selectable analog/digital inputs
	Digital inputs type	Pull-up
Drive specifications	Analog inputs: two	0-10 VDC, 4 to 20mA
	Relay output: one	Built-in form C relay
	Analog output / digital output	0-10 VDC: one analog usable for meter (freq., current, voltage) or digital output
	Overload capacity	Drive output 150% for one minute and 175% for 2 seconds
	Maximum load	1.5 HP @ 120 V In/230 V Out, 20 HP @ 600 V In/Out
	Input voltage ranges	115 VAC (99-126); 600 VAC (450-660)
	Rated input frequency	50-60 Hz (±5%)
	Carrier frequency	4-32 kHz (8 kHz default)
	Operating temperature	-10° to 50°C
	Snubber (dynamic braking)	Built-in transistor (frames 2 and 3)
	Dynamic braking external	Up to 150% dynamic braking with appropriately sized resistor
	DC injection braking	Included
	Volts/Hz	Linear V/Hz, user defined, energy optimizer & boost function
	Sensorless vector	Speed and torque with autotune for AC induction and permanent magnet motors
	Frequency control range	0-500 Hz
	Accel/decel:	Independently adjustable accel. & decel. ramps
	Time range	0.00 to 600.0 Seconds
	Keypad speed control	Yes
	Sink/source inputs	Source, 24 VDC logic
	Electronic overload trip	Electronic motor overload inverse 150% for 1 minute or 175% for 2 seconds
Communications	Built-in Modbus-RTU (RS-485) communications	
PI control	Built-in	
Protective features	Under voltage	Level depends on voltage class
	Output short circuit	Phase-to-phase on drive output
	Over temperature	Heat sink monitor
	DC bus overvoltage	DC bus level trip
	Drive overload	Exceed drive rating of 150% for one minute or 175% for 2 seconds
	Over current	Over-current/short-circuit protection
	Output phase	Trips on open output phase
	Loss of reference	Trips on loss of speed command signal
	Communication error	Detects a communication error (fault)
Agency certifications	UL, cUL, CE, C-tick, gost	
Service conditions	Altitude	1,000 m (3,300 ft.), derate by 1% per 100M up to 2,000 on maximum
	Ambient temperature	-10°C (14°F) to 50°C (102°F)
	Storage temperature:	-40°C (-40°F) to 60°C (140°F)
	Relative humidity	10% to 95%, non-condensing

ACS255 IP20 micro drive

Ratings and types

Type designation

This is the unique reference number (shown above and in the first column, below) that clearly identifies your drive by power rating and frame size. Once the drive's type designation has been selected, the frame size (column 7) can be used to determine the drive dimensions, shown on the next page.

Voltages

ACS255 is available in two voltage ranges:

1 = 110 to 120 V

6 = 500 to 600 V

Insert either "1" or "6", depending on your chosen voltage, into the type designation shown above.

Construction

"01U" within the type designation (shown above) varies depending on the drive phase and EMC filtering. Choose below the one you need.

01 = 1-phase

03 = 3-phase

U = No EMC filter

Type code	Braking chopper (included)	P_N	P_N	Output current I_{2N}	Weight	Frame size
		HP	kW		A	
1-phase supply voltage 110 to 120 V, +/-10%, 3-phase output 200 to 240 V						
ACS255-01U-02A3-1	---	0.5	0.37	2.3	2.2	E1
ACS255-01U-04A3-1	---	1	0.75	4.3	2.2	E1
ACS255-01U-05A8-1	STD	1.5	1.1	5.8	3.75	E2
3-phase supply voltage 500 to 600 V, +/-10%						
ACS255-03U-02A1-6	STD	1	0.75	2.1	4.0	P2
ACS255-03U-03A1-6	STD	2	1.5	3.1	4.0	P2
ACS255-03U-04A1-6	STD	3	2.2	4.1	4.0	P2
ACS255-03U-06A5-6	STD	5	4.0	6.5	4.0	P2
ACS255-03U-09A0-6	STD	7.5	5.5	9	4.0	P2
ACS255-03U-12A0-6	STD	10	7.5	12	7.7	P3
ACS255-03U-17A0-6	STD	15	11	17	7.7	P3
ACS255-03U-22A0-6	STD	20	15	22	7.7	P3

Notes:

I_{2N} : continuous base current with 110% overload for 1 minute / 10 minutes.

P_N : Typical motor power for most 4-pole NEMA motors in normal use.

ACS255 IP20 micro drive

Dimensions and weights

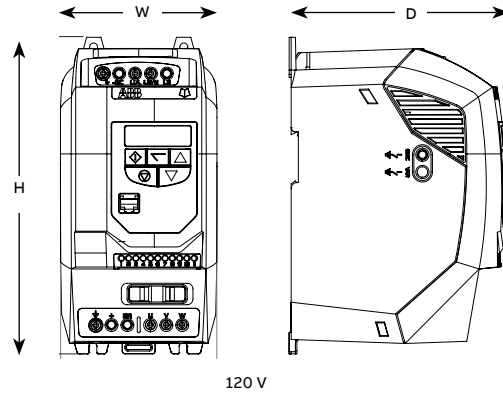

IP20 120V

Frame size	Height		Width		Depth		Weight		Dimension drawing
	in	mm	in	mm	in	mm	lb	kg	
E1	6.81	173	3.23	82	4.84	123	2.20	1	3AXD10000274006
E2	8.70	221	4.29	109	5.91	150	3.75	1.70	3AXD10000274008

H = Height
W = Width
D = Depth

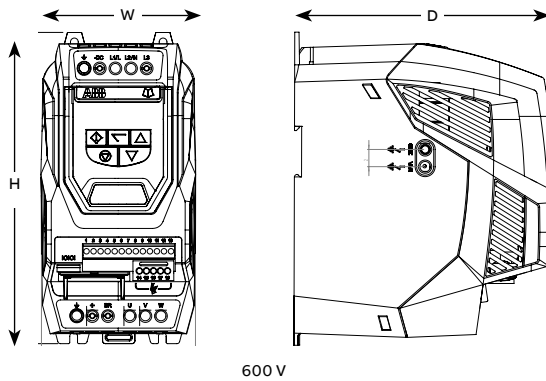

IP20 600V

Frame size	Height		Width		Depth		Weight		Dimension drawing
	in	mm	in	mm	in	mm	lb	kg	
P2	8.70	221	4.41	112	7.28	185	4	1.80	3AXD10000274014
P3	10.28	261	5.16	131	8.07	205	7.70	3.50	3AXD10000274016

H = Height
W = Width
D = Depth

ACS255 IP66 micro drive

Overview

Screws, mixers, pumps, fans and conveyors are commonly installed in harsh environments containing dust, moisture and chemicals. The IP66/NEMA 4X ACS255 was designed to thrive in these types of conditions. The drive's design and ease of setup benefit a broad range of industries that require machine mounted drives.

Hygienic protection

The drive was designed with materials that meet stringent hygiene standards, preventing the drive from trapping bacteria. The integrated keypad provides straightforward drive commissioning and maintenance in extreme environments. The drive's sealed ABS enclosure and corrosion-resistant heat sink are ideal for wash-down applications.

Main features

- Built-in macros and only the essential parameters make commissioning straightforward
- Can be mounted directly on processing equipment installed in extreme environments
- Conduit cable entry
- Intuitive keypad control
- Optional switch features; speed potentiometer, FWD-OFF-REV and disconnect switches
- IP66/NEMA 4X dust and waterproof design
- Designed for wash-down applications
- Specially coated corrosion-resistant heat sink
- Sealed top cover with separate terminal access cover provides ready access without exposing components
- Widely spaced heat sink fans with no external fans to fail or get clogged in washdown environments
- Modbus-RTU fieldbus as standard
- Built-in brake chopper (except frame E1)
- Safe torque off function (SIL2) which can be used as emergency stop or to prevent unexpected startup (600 V only)
- Open loop vector speed and vector torque control mode for AC induction and permanent magnet motors - all ACS255 drives
- Operating Mode Select quickly configures current limit, torque characteristic and spin start parameters for Industrial, Pump, or Fan applications

Applications

- Variable torque, constant torque or constant horsepower applications in harsh environments or requiring on machine mounting

Capabilities

- NEMA 4X IP66 enclosure for indoor use
- V/Hz control with peak overload capacity of 175%
- Embedded Modbus-RTU
- Intuitive integrated keypad
- Designed to be easy to program for simple machine interface local control & disconnect

ACS255 IP66 micro drive

Dimensions and weights

Performance features	Control modes	115-460 VAC: V/Hz and open loop vector 600 VAC: V/Hz and open loop vector
	Operator interface module	Integral drive mounted
	Display lines	6-character LED display
	Programmable preset speeds	Four
	Analog output: one	One (0-10 VDC)
	Auto restart	Yes- Up to 5 attempts
	Frequency avoidance	One band
	Fault history	Last four faults
	Digital Inputs: four	Three configurable inputs
	Digital inputs type	Pull-up
Drive specifications	Analog inputs: two	0-10 VDC, 4 to 20mA
	Relay output: one	One built-in form C relay
	Analog output / digital output	0-10 VDC: one analog usable for meter (freq., current, voltage) or digital output
	Maximum load	5 HP @ 230 VAC, 10 HP @ 460 VAC, 15 HP @ 600 VAC
	Overload capacity	Drive output 150% for one minute and 175% for 2 seconds
	Input voltage ranges	115 VAC (99-126); 230 VAC (198-264); 460 VAC (342-528); 600 VAC (450-660)
	Rated input frequency	50-60 Hz (±5%)
	Carrier frequency	4-32 kHz (8 kHz default)
	Operating temperature	-10° to 40°C
	Snubber (dynamic braking)	Built-in transistor (frames 2 and 3)
	Dynamic braking external	Up to 150% dynamic braking with appropriately sized resistor
	DC injection braking	Included
	Volts/Hz	Linear V/Hz, user defined, energy optimizer & boost function
	Sensorless vector	Speed and torque with autotune for AC induction and permanent magnet motors
	Frequency control range	0-500 Hz
	Accel/decel:	Independently adjustable accel. & decel. ramps
	Time range	0.00 to 600.0 seconds
	Keypad speed control	Yes
	Sink/source inputs	Source, 24 VDC logic
	Electronic overload trip	Electronic motor overload inverse 150% for 1 minute or 175% for 2 seconds
Communications	Built-in Modbus-RTU (RS-485) communications	
PI control	Built-in	
Protective features	Under voltage	Level depends on voltage class (120, 240, 480, or 575)
	Output short circuit	Phase-to-phase on drive output
	Over temperature	Heat sink monitor
	DC bus overvoltage	DC Bus level trip
	Drive overload	Exceed drive rating of 150% for one minute or 175% for 2 seconds
	Over current	Over-current/short-circuit protection
	Output phase	Trips on open output phase
	Loss of reference	Trips on loss of speed command signal
	Communication error	Detects a communication error (fault)
Agency certifications		UL, cUL, CE, C-tick, Gost
Service conditions	Altitude	1,000 m (3,300 ft.), derate by 1% per 100M up to 2,000m maximum
	Ambient temperature	-10°C (14°F) to 40°C (122°C)
	Storage temperature:	-40°C (-40°F) to 60°C (140°F)
	Relative humidity	10% to 95%, non-condensing
	Intermittent overload	150% overload capacity for up to 1 minute, 175% overload capacity for up to 2 seconds

ACS255 IP66 micro drive

Ratings and types

Type designation

This is the unique reference number (shown above and in the first column, below) that clearly identifies your drive by power rating and frame size. Once the drive's type designation has been selected, the frame size (column 7) can be used to determine the drive dimensions, shown on the next page.

Insert either "1", "2", "4" or "6", depending on your chosen voltage, into the type designation shown above.

Construction

"01U" within the type designation (shown above) varies depending on the drive phase and EMC filtering. Choose below the one you need.

Voltages

ACS255 is available in two voltage ranges:

- 1 = 110 to 120 V
- 2 = 200 to 240 V
- 4 = 380 to 480 V
- 6 = 500 to 600 V

- 01 = 1-phase
- 03 = 3-phase
- U = No EMC filter
- F278 = Operator controls: Disconnect, FWD/REV/OFF selector, Speed Potentiometer

Type code	Braking chopper (included)	P _N	P _N	Output current I _{2N} A	Weight lb	Frame size
		HP	kW			
1-phase supply voltage 110 to 120V, +/-10%, 3-phase output 200 to 240 V						
ACS255-01U-02A3-1+B063(+F278)	-	0.5	0.37	2.3	6.5	E1
ACS255-01U-04A3-1+B063(+F278)	-	1.0	0.75	4.3	6.5	E1
ACS255-01U-05A8-1+B063(+F278)	X	1.5	1.1	5.8	9.3	E2
1-phase supply voltage 200 to 240V, +/-10%, 3-phase output 200 to 240 V						
ACS255-01U-02A3-2+B063(+F278)	-	0.5	0.37	2.3	6.5	E1
ACS255-01U-04A3-2+B063(+F278)	-	1.0	0.75	4.3	6.5	E1
ACS255-01U-06A1-2+B063(+F278)	-	1.5	1.1	6.1	6.5	E1
ACS255-01U-07A0-2+B063(+F278)	-	2.0	1.5	7.0	6.5	E1
ACS255-01U-10A5-2+B063(+F278)	X	3.0	2.2	10.5	9.3	E2
ACS255-01U-15A3-2+B063(+F278)	X	5.0	3.7	15.3	17.0	E3
3-phase supply voltage 200 to 240 V, +/-10%						
ACS255-03U-02A3-2+B063(+F278)	-	0.5	0.37	2.3	6.5	E1
ACS255-03U-04A3-2+B063(+F278)	-	1.0	0.75	4.3	6.5	E1
ACS255-03U-06A1-2+B063(+F278)	-	1.5	1.10	6.1	6.5	E1
ACS255-03U-07A0-2+B063(+F278)	X	2.0	1.5	7.0	9.3	E2
ACS255-03U-10A5-2+B063(+F278)	X	3.0	2.2	10.5	9.3	E2
ACS255-03U-18A0-2+B063(+F278)	X	5.0	4.0	18.0	17.0	E3
3-phase supply voltage 380 to 480 V, +/-10%						
ACS255-03U-01A2-4+B063(+F278)	-	0.5	0.37	1.2	6.5	E1
ACS255-03U-02A2-4+B063(+F278)	-	1.0	0.75	2.2	6.5	E1
ACS255-03U-03A3-4+B063(+F278)	-	1.5	1.1	3.3	6.5	E1
ACS255-03U-04A1-4+B063(+F278)	-	2.0	1.5	4.1	6.5	E1
ACS255-03U-05A8-4+B063(+F278)	X	3.0	2.2	5.8	9.3	E2
ACS255-03U-09A5-4+B063(+F278)	X	5.0	4.0	9.5	9.3	E2
ACS255-03U-14A0-4+B063(+F278)	X	7.5	5.5	14.0	17.0	E3
ACS255-03U-18A0-4+B063(+F278)	X	10.0	7.5	18.0	17.0	E3
3-phase supply voltage 500 to 600 V, +/-10%						
ACS255-03U-02A1-6+B063(+F278)	X	1.0	0.75	2.1	10.6	P2
ACS255-03U-03A1-6+B063(+F278)	X	2.0	1.5	3.1	10.6	P2
ACS255-03U-04A1-6+B063(+F278)	X	3.0	2.2	4.1	10.6	P2
ACS255-03U-06A5-6+B063(+F278)	X	5.0	4.0	6.5	10.6	P2
ACS255-03U-09A0-6+B063(+F278)	X	7.5	5.5	9.0	10.6	P2
ACS255-03U-12A0-6+B063(+F278)	X	10.0	7.5	12.0	16.1	P3
ACS255-03U-17A0-6+B063(+F278)	X	15.0	11.0	17.0	16.1	P3

P_N for kW = Typical motor power in 400 V at normal use
P_N for hp = Typical motor power in 460 V at normal use
I_{2N} for A = Continuous rms current. 50% overload is allowed for one minute in ten minutes.

ACS255 IP66 micro drive

Dimensions and weights

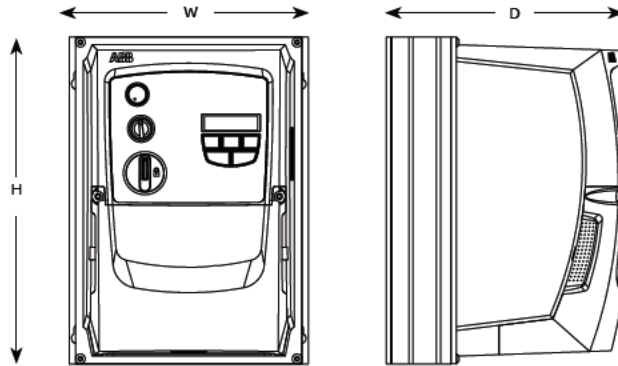

120, 240, 480 V

IP66 120, 240, 480V

Frame size	Height		Width		Depth		Weight		Dimension drawing
	in	mm	in	mm	in	mm	lb	kg	
E1	9.13	232	6.34	161	7.05	179	6.50	2.95	3AXD10000274009
E2	10.12	257	7.40	188	7.34	186	9.26	4.20	3AXD10000274011
E3	12.20	310	8.29	210	9.00	229	16.97	7.70	3AXD10000274012

H = Height

W = Width

D = Depth

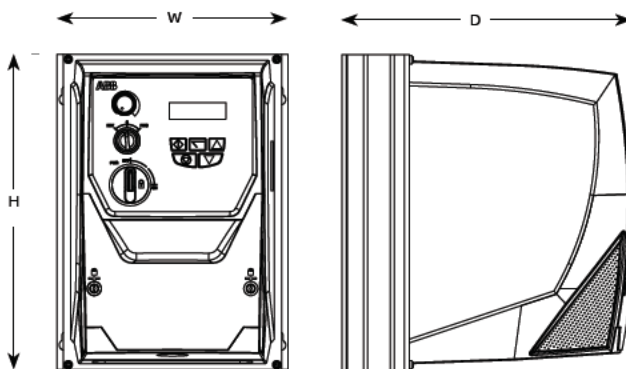

600 V

IP66 600V

Frame size	Height		Width		Depth		Weight		Dimension drawing
	in	mm	in	mm	in	mm	lb	kg	
P2	10.12	257	7.40	188	9.41	239	10.60	4.80	3AXD10000274017
P3	12.20	310	8.29	211	9.88	251	16.10	7.30	3AXD10000274018

H = Height

W = Width

D = Depth

Cooling

Cooling air flow for IP20 drives

IP20 drives are designed to be installed in a protective enclosure. Heat dissipation and air flow values are given to assist with sizing enclosure sizes and cooling provisions. ACS255 drives 1 HP and above are fitted with heat sink cooling fans as standard. Drives below 1 HP do not have an

internal cooling fan and rely on natural convection to cool the internal components. The cooling air must be free from corrosive substances and must not be above the maximum ambient temperature of 40 °C (50 °C with derating on IP20 drives only). For more specific limits see the individual Data Sheet pages (for IP20 & IP66 drives) in this catalog.

Cooling air flow

Type designation	Frame size	Heat dissipation		Air flow	
		W	BTU/hr	m ³ /h	ft ³ /min
1-phase AC supply, 110 to 120 V					
ACS255-01U-02A3-1	E1	11	38	19	11
ACS255-01U-04A3-1	E1	23	77	19	11
ACS255-01X-05A8-1	E2	33	113	44	26
3-phase AC supply, 500 to 600 V					
ACS255-03U-02A1-6	P2	23	77	19	11
ACS255-03U-03A1-6	P2	45	154	19	11
ACS255-03U-04A1-6	P2	66	225	19	11
ACS255-03U-06A5-6	P2	120	409	19	11
ACS255-03U-09A0-6	P2	165	563	19	11
ACS255-03U-12A0-6	P3	225	768	44	26
ACS255-03U-17A0-6	P3	330	1126	44	26
ACS255-03U-22A0-6	P3	450	1535	44	26

Note: IP66 drives are designed to be mounted outside of an enclosure. The heat sink is designed for maximum cooling with natural convected airflow.

Free Space Requirements

Enclosure Type	Frame size	Space Above & Below (X)		Space Either Side (Y)		Space Between (Z) ¹	
		in	mm	in	mm	in	mm
IP20	1	1.97	50	1.97	50	1.30	33
IP20	2	2.95	75	1.97	50	1.81	46
IP20	3	3.94	100	1.97	50	2.05	52
IP66	All	7.87	200	0.39	10	0	0

Notes:

1) Dimension Z assumes that the drives are mounted side by side with no clearance. For the IP66 drives, can be installed side-by-side with the heatsink flanges touching. This gives adequate ventilation space between drives.

2) Drive must be installed on a vertical flat surface that is able to support the weight of the drive.

3) Spacing requirements are guidelines only and do not take into account other sources of heat in the environment. Operating ambient temperature of the drive must be maintained at all times.

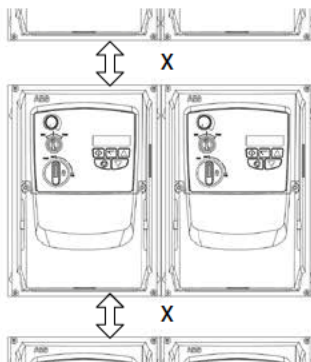
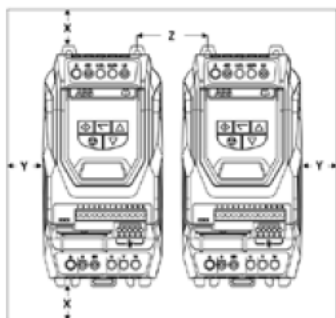

Fuses and cable sizes

The following table provides the output current rating information for the various ACS255 models. ABB Drives always recommend that selection of the correct ACS255 is based upon the motor full load current at the incoming supply voltage.

Cable dimensioning for nominal rated currents is shown in the table below together with the corresponding fuse types for short-circuit protection of the input power cable.

The rated fuse currents given in the table are the maximums for the mentioned fuse types. If smaller

fuse ratings are used, check that the fuse rms current rating is larger than the nominal input current. If 150% output power is needed, multiply nominal input current by 1.5.

Check that the operating time of the fuse is below 0.5 seconds. The operating time depends on the fuse type, the supply network impedance as well as the cross-sectional area, material and length of the supply cable. In case the 0.5 seconds operating time is exceeded with the gG or T fuses, ultra rapid (aR) fuses in most cases reduce the operating time to an acceptable level.

Type Code	Power HP	Fuse		Maximum Supply and PE Cable Size		Nominal Output Current A	Motor Cable Size		Max Motor Cable Length m	Frame Size
		A	UL Class CC or J	mm ²	AWG		mm ²	AWG		
1-phase 110V...115V AC (+/-10%) - 3 Phase 230V Output										
ACS255-01U-02A3-1	0.5	10	10	8	8	2.3	1.5	14	100	E1
ACS255-01U-04A3-1	1	25	20	8	8	4.3	1.5	14	100	E1
ACS255-01U-05A8-1	1.5	32	30	8	8	5.8	1.5	14	100	E2
1-phase 200...240V AC (+/-10%) - 3 Phase Output										
ACS255-01U-02A3-2	0.5	10	6	8	8	2.3	1.5	14	100	E1
ACS255-01U-04A3-2	1	10	10	8	8	4.3	1.5	14	100	E1
ACS255-01U-06A1-2	1.5	16	15	8	8	6.1	1.5	14	100	E1
ACS255-01U-07A0-2	2	16	17.5	8	8	7	1.5	14	100	E2
ACS255-01U-10A5-2	3	25	25	8	8	10.5	1.5	14	100	E2
ACS255-01U-15A3-2	5	40	40	8	8	15.3	4	10	100	E3
3-phase 200...240V AC (+/-10%) - 3 Phase Output										
ACS255-03U-02A3-2	0.5	6	6	8	8	2.3	1.5	14	100	E1
ACS255-03U-04A3-2	1	10	10	8	8	4.3	1.5	14	100	E1
ACS255-03U-06A1-2	1.5	10	15	8	8	6.1	1.5	14	100	E1
ACS255-03U-07A0-2	2	16	15	8	8	7	1.5	14	100	E2
ACS255-03U-10A5-2	3	16	17.5	8	8	10.5	1.5	14	100	E2
ACS255-03U-18A0-2	5	32	30	8	8	18	2.5	10	100	E3
3-phase 380...480V AC (+/-10%) - 3 Phase Output										
ACS255-03U-01A2-4	0.5	6	6	8	8	1.2	1.5	14	100	E1
ACS255-03U-02A2-4	1	6	6	8	8	2.2	1.5	14	100	E1
ACS255-03U-03A3-4	1.5	10	10	8	8	3.3	1.5	14	100	E1
ACS255-03U-04A1-4	2	10	10	8	8	4.1	1.5	14	100	E2
ACS255-03U-05A8-4	3	16	10	8	8	5.8	1.5	14	100	E2
ACS255-03U-09A5-4	5	16	15	8	8	9.5	1.5	14	100	E2
ACS255-03U-14A0-4	7.5	25	25	8	8	14	1.5	12	100	E3
ACS255-03U-18A0-4	10	32	30	8	8	18	2.5	10	100	E3
3-phase 500...600V AC (+/-10%) - 3 Phase Output										
ACS255-03U-02A1-6	1	10	6	1.5	14	2.1	1.5	14	100	P2
ACS255-03U-03A1-6	2	10	6	1.5	14	3.1	1.5	14	100	P2
ACS255-03U-04A1-6	3	10	10	1.5	14	4.1	1.5	14	100	P2
ACS255-03U-06A5-6	5	10	10	1.5	14	6.5	1.5	14	100	P2
ACS255-03U-09A0-6	7.5	16	15	2.5	12	9	1.5	14	100	P2
ACS255-03U-12A0-6	10	25	20	4	10	12	1.5	14	100	P3
ACS255-03U-17A0-6	15	25	25	4	8	17	2.5	10	100	P3
ACS255-03U-22A0-6	20	40	35	10	8	22	4	10	100	P3

Notes:

1) Larger fuses must not be used when the input power cable is selected according to this table.

2) For UL compliant installation, use Copper wire with a minimum insulation temperature rating of 70°C, UL Class CC or Class J Fuses

3) Other fuse types can be used if they meet the ratings and the melting curve of the fuse does not exceed the melting curve of the fuse mentioned in this table.

4) The maximum motor cable length stated applies to using a shielded motor cable. When using an unshielded cable, the maximum cable length limit may be increased by 50%. When using the ABB Drives recommended output choke, the maximum cable length may be increased by 100%

5) The PWM output switching from any inverter when used with a long motor cable length can cause an increase in the voltage at the motor terminals, depending on the motor cable length and inductance. The rise time and peak voltage can affect the service life of the motor. ABB Drives recommend using an output choke for motor cable lengths of 50m or more to ensure good motor service life

Control connections

115, 240, 480 V drives

IP66 (NEMA 4X) Switched Units

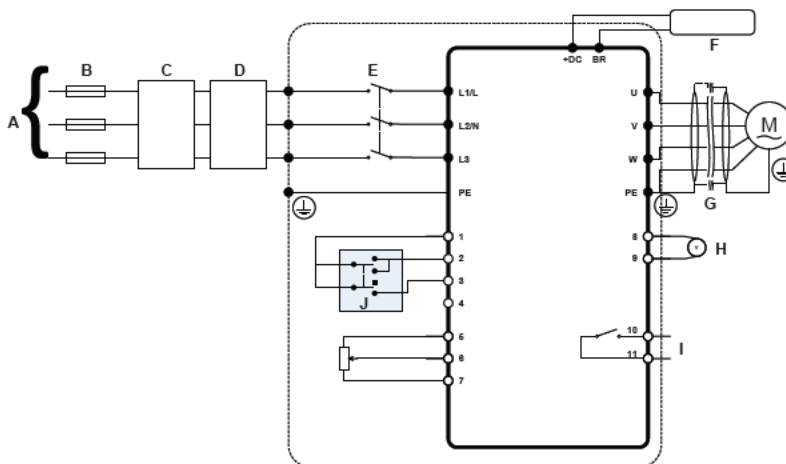

Power Connections	
A	Incoming Power Source
B	External Fuse
C	Optional Input Choke
D	Optional Input Filter
E	Internal Mains Disconnect
F	Optional Brake Resistor
G	Shielded Motor Cable
I	Relay Output
Control Connections	
J	Internal Forward / Off / Reverse Switch
K	Internal Speed Control Pot
8	Analog Output: 0 – 10 Volts
9	0 Volt
10	Relay Output
11	'Drive READY' = Closed

IP20 & IP66 (NEMA 4X) Non-Switched Units

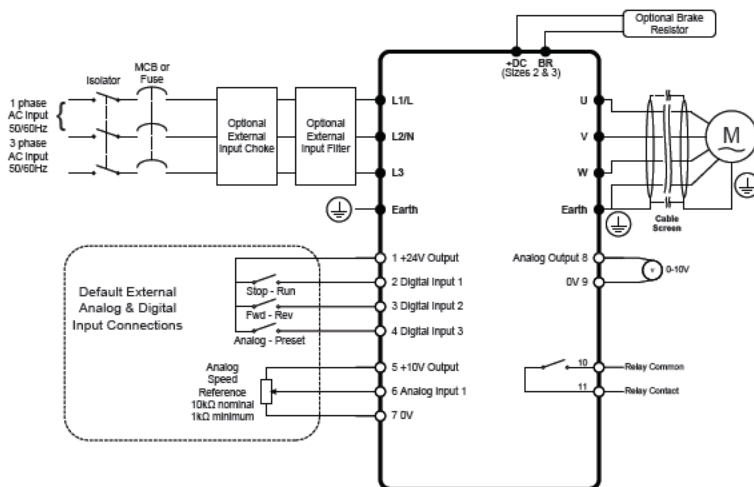

Power Connections	
A	Incoming Power Source
B	External Mains Disconnect
C	External Fuse
D	Optional Input Choke
E	Optional Input Filter
F	Optional Brake Resistor
G	Shielded Motor Cable
I	Relay Output
Control Connections	
1	+ 24 Volt (100mA) User Output
2	Digital Input 1: Drive Run / Stop
3	Digital Input 2: Forward / Reverse
4	Digital Input 3: Analog / Preset Speed
5	+ 10 Volt Output
6	Analog Input 1: 0 – 10 Volt
7	0 Volt
8	Analog Output: 0 – 10 Volts
9	0 Volt
10	Relay Output
11	'Drive READY' = Closed

Typical I/O Connections

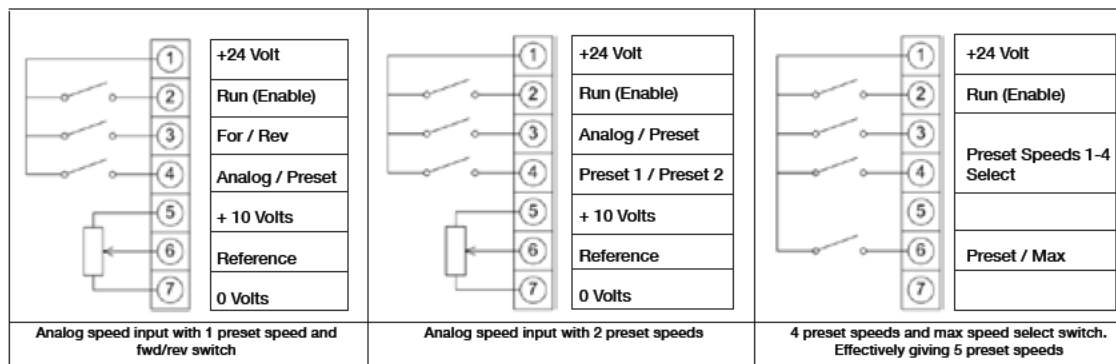

Control connections

600V drives

Power Terminal Designations

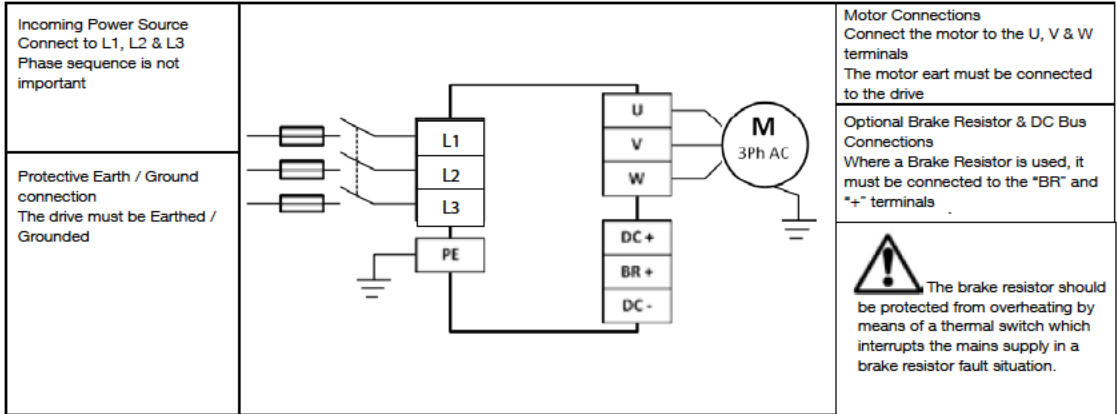

Control Terminal Connections & Factory Settings

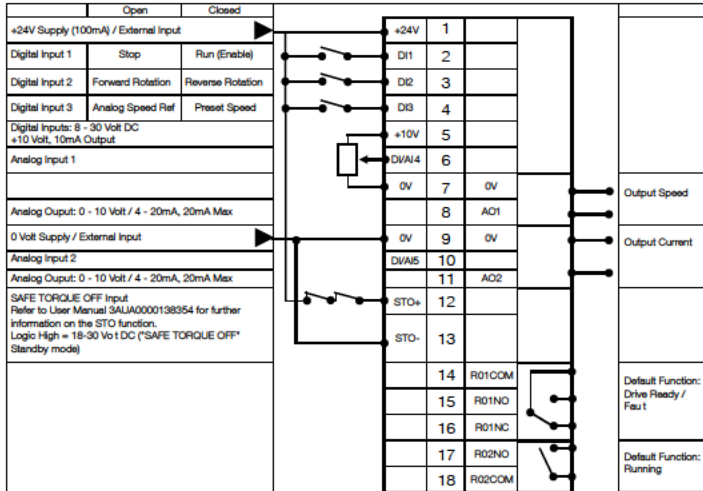

Typical I/O Connections

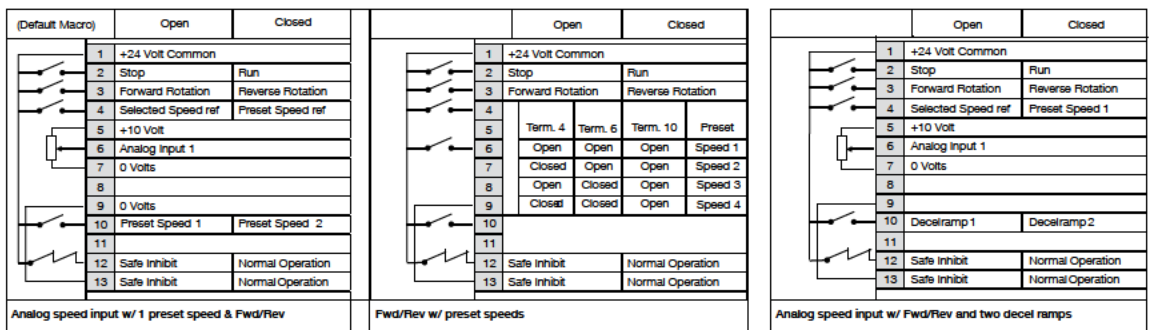

Options

Model	Code	Field kit	Description
RCCS-01 copying tool	N/A	RCCS-01	Copy stick, which is used to upload and download the parameters through RJ45 connection Parameters can only be copied between drives of the same product range and power rating (size)
RCRO-01 relay output card	N/A	RCRO-01	The second relay output module can be used in applications where the analog output from the drive is converted to a relay output. Max relay switching voltage: 255 VAC/220 VDC Max relay switching current: 1A Max input voltage: +/- 50 VDC Environmental: -10°C ... +50°C Conformity: IP00, UL94V-0 Not compatible with 600 V drives
RCRP-02 external LED keypad	N/A	RCRP-02	Remote keypad that can be added through RJ45 connection. Signal interface: standard 6-way RJ45 connector Supply input: 10V ... 36 VDC, 30mA RS485 signal: industry standard 2-wire +5V differential Environmental: operational 0 ... 50 °C Storage: -40°C ... 60°C Relative humidity: < 95% (non condensing) Protection rating: IP54 Max cable length: 20m (unscreened, total length) 100m (screened, twisted pair, total length)
RCRJ-01 RJ45 Y-cable splitter	N/A	RCRJ-01	The data cable splitter is a 3-way "Y" cable splitter suitable for a RS-485 network of drives. The option is compatible with standard CAT 5 or CAT 6 type cable and can be used for Modbus-RTU or an RS-485 remote keypad network.
RCNT-01 RJ45 Y-cable splitter w/ term.	N/A	RCNT-01	The data cable splitter with terminal block is a 3-way "Y" cable splitter with one terminal block suitable for an RS-485 network of drives. Two of the three connections are compatible with standard CAT 5 or CAT 6 type cable and the third is a terminal block that can be used to connect a PLC or network terminating resistor.
ACS255 democase	N/A	ACS255-IP20 DEMOCASE	Powered by 115 VAC, the program case does includes an ACS255 drive and IO board with switches, speed potentiometer and LED. Ideal for demonstrating the programability of the ACS255. There is no motor included in this democase
N/A	+F278	N/A	Operator controls assembled on the front cover of the drive: Disconnect, FWD/OFF/REV selector, and speed potentiometer. Available on IP66 drives only.

NOTE:

- 1) Options are shipped separately and not available pre-assembled on the drive unless noted with a plus code.
- 2) ACS255 not compatible with previously offered RCRP-01. Use RCRP=01 only with ACS250.

Braking resistors

Single-phase 100-120 V and 200-240V applications, stopping duty only

100-120 V

Type CR resistors (available for the small HP drives as listed below)

		DutyCycle=3sec on/27sec off			DutyCycle=10sec on/50sec off		
Drive type code	HP	CR part no.	Ohms	Watts	CR part no.	Ohms	Watts
ACS255-01U-05A8-1	1.5	P14494-CR-06	50	100	P14494-CR-18	50	200
		DutyCycle=30sec on/180sec off			DutyCycle=60sec on/180sec off		
Drive type code	HP	CR part no.	Ohms	Watts	CR part no.	Ohms	Watts
ACS255-01U-05A8-1	1.5	P14494-CR-24	50	300	P14494-CR-32	50	400

Standard enclosed resistor packages

		DutyCycle=3sec on/27sec off			DutyCycle=10sec on/50sec off		
Drive type code	HP	Resistor part no.	Ohms	Watts	Resistor part no.	Ohms	Watts
ACS255-01U-05A8-1	1.5	P14494-24	45	300	P14494-24	45	300
		DutyCycle=30sec on/180sec off			DutyCycle=60sec on/180sec off		
Drive type code	HP	Resistor part no.	Ohms	Watts	Resistor part no.	Ohms	Watts
ACS255-01U-05A8-1	1.5	P14494-24	45	300	P14494-24	45	300

Notes: To determine resistor type, dimensions and weights refer to Resistor Technical Data Tables

200-240 V

Type CR resistors (available for the small HP drives as listed below)

		DutyCycle=3sec on/27sec off			DutyCycle=10sec on/50sec off		
Drive type code	HP	CR part no.	Ohms	Watts	CR part no.	Ohms	Watts
ACS255-01U-10A5-2	3	P14494-CR-12	50	150	P14494-CR-24	50	300
ACS255-01U-15A3-2	5	P14494-CR-54	18	300	P14494-CR-56	18	500
		DutyCycle=30sec on/180sec off			DutyCycle=60sec on/180sec off		
Drive type code	HP	CR part no.	Ohms	Watts	CR part no.	Ohms	Watts
ACS255-01U-10A5-2	3	P14494-CR-32	50	400			

Standard enclosed resistor packages

		DutyCycle=3sec on/27sec off			DutyCycle=10sec on/50sec off		
Drive type code	HP	Resistor part no.	Ohms	Watts	Resistor part no.	Ohms	Watts
ACS255-01U-10A5-2	3	P14494-24	45	300	P14494-24	45	300
ACS255-01U-15A3-2	5	P14494-73	30	350	ABB-48431-080	30	800
		DutyCycle=30sec on/180sec off			DutyCycle=60sec on/180sec off		
Drive type code	HP	Resistor part no.	Ohms	Watts	Resistor part no.	Ohms	Watts
ACS255-01U-10A5-2	3	P14494-25	45	800	P14494-32	45	800
ACS255-01U-15A3-2	5	ABB-48431-080	30	800	P14494-60	30	1050

Notes: To determine resistor type, dimensions and weights refer to Resistor Technical Data Tables

Braking resistors

Three-phase 200-240 V applications, stopping duty only

Type CR resistors (available for the small HP drives as listed below)

Drive type code	HP	DutyCycle=3sec on/27sec off			DutyCycle=10sec on/50sec off		
		CR part no.	Ohms	Watts	CR part no.	Ohms	Watts
ACS255-03U-07A0-2	2	P14494-CR-06	50	100	P14494-CR-18	50	200
ACS255-03U-10A5-2	3	P14494-CR-12	50	150	P14494-CR-24	50	300
ACS255-03U-18A0-2	5	P14494-CR-26	40	300	P14494-CR-34	40	400
Drive type code	HP	DutyCycle=30sec on/180sec off			DutyCycle=60sec on/180sec off		
		CR part no.	Ohms	Watts	CR part no.	Ohms	Watts
ACS255-03U-07A0-2	2	P14494-CR-24	50	300	P14494-CR-32	50	400
ACS255-03U-10A5-2	3	P14494-CR-32	50	400			

Standard enclosed resistor packages

Drive type code	HP	DutyCycle=3sec on/27sec off			DutyCycle=10sec on/50sec off		
		Resistor part no.	Ohms	Watts	Resistor part no.	Ohms	Watts
ACS255-03U-07A0-2	2	P14494-31	35	300	P14494-31	35	300
ACS255-03U-10A5-2	3	P14494-31	35	300	P14494-31	35	300
ACS255-03U-18A0-2	5	P14494-73	30	350	ABB-48431-080	30	800
Drive type code	HP	DutyCycle=30sec on/180sec off			DutyCycle=60sec on/180sec off		
		Resistor part no.	Ohms	Watts	Resistor part no.	Ohms	Watts
ACS255-01U-07A0-2	2	P14494-31	35	300	P14494-32	35	820
ACS255-01U-10A5-2	3	P14494-32	35	820	P14494-32	35	820
ACS255-03U-18A0-2	5	ABB-48431-080	30	800	P14494-60	30	1050

Notes: To determine resistor type, dimensions and weights refer to Resistor Technical Data Tables

Braking resistors

Three-phase 380-480 V applications, stopping duty only

Type CR resistors (available for the small HP drives as listed below)

		DutyCycle=3sec on/27sec off			DutyCycle=10sec on/50sec off		
Drive type code	HP	CR part no.	Ohms	Watts	CR part no.	Ohms	Watts
ACS255-03U-04A1-4	2	P14494-CR-03	150	100	P14494-CR-15	150	200
ACS255-03U-05A8-4	3	P14494-CR-11	100	150	P14494-CR-22	100	300
ACS255-03U-09A5-4	5	P14494-CR-22	100	300	P14494-CR-30	100	400
ACS255-03U-14A0-4	7.5	P14494-CR-32	50	400			
		DutyCycle=30sec on/180sec off			DutyCycle=60sec on/180sec off		
Drive type code	HP	CR part no.	Ohms	Watts	CR part no.	Ohms	Watts
ACS255-03U-04A1-4	2	P14494-CR-21	150	300	P14494-CR-29	150	400
ACS255-03U-05A8-4	3	P14494-CR-30	100	400			

Standard enclosed resistor packages

		DutyCycle=3sec on/27sec off			DutyCycle=10sec on/50sec off		
Drive type code	HP	Resistor part no.	Ohms	Watts	Resistor part no.	Ohms	Watts
ACS255-03U-04A1-4	2	P14494-15	150	300	P14494-15	150	300
ACS255-03U-05A8-4	3	P14494-15	150	300	P14494-15	150	300
ACS255-03U-09A5-4	5	P14494-19	75	300	P14494-20	75	600
ACS255-03U-14A0-4	7.5	P14494-25	45	800	P14494-25	45	800
ACS255-03U-18A0-4	10	P14494-25	45	800	P14494-26	45	1260
		DutyCycle=30sec on/180sec off			DutyCycle=60sec on/180sec off		
Drive type code	HP	Resistor part no.	Ohms	Watts	Resistor part no.	Ohms	Watts
ACS255-03U-04A1-4	2	P14494-15	150	300	P14494-16	150	600
ACS255-03U-05A8-4	3	P14494-16	150	600	P14494-16	150	600
ACS255-03U-09A5-4	5	P14494-20	75	600	P14494-21	75	1000
ACS255-03U-14A0-4	7.5	P14494-26	45	1260	P14494-27	45	1920
ACS255-03U-18A0-4	10	P14494-26	45	1260	P14494-27	45	1920

Notes: To determine resistor type, dimensions and weights refer to Resistor Technical Data Tables

Braking resistors

Three-phase 575-600 V applications, stopping duty only

Type CR resistors (available for the small HP drives as listed below)

		DutyCycle=3sec on/27sec off			DutyCycle=10sec on/50sec off		
Drive type code	HP	CR part no.	Ohms	Watts	CR part no.	Ohms	Watts
ACS255-03U-02A1-6	1.5	P14494-CR-02	200	100	P14494-CR-13	250	200
ACS255-03U-03A1-6	2	P14494-CR-08	250	150	P14494-CR-19	250	300
ACS255-03U-04A1-6	3	P14494-CR-22	100	300	P14494-CR-30	100	400
ACS255-03U-06A5-6	5	P14494-CR-22	100	300			
		DutyCycle=30sec on/180sec off			DutyCycle=60sec on/180sec off		
Drive type code	HP	CR part no.	Ohms	Watts	CR part no.	Ohms	Watts
ACS255-03U-02A1-6	1.5	P14494-CR-19	250	300	P14494-CR-27	250	400
ACS255-03U-03A1-6	2	P14494-CR-19	250	300	P14494-CR-27	250	400
ACS255-03U-04A1-6	3	P14494-CR-27	250	400			

Standard enclosed resistor packages

		DutyCycle=3sec on/27sec off			DutyCycle=10sec on/50sec off		
Drive type code	HP	Resistor part no.	Ohms	Watts	Resistor part no.	Ohms	Watts
ACS255-03U-02A1-6	1.5	P14494-11	250	300	P14494-11	250	300
ACS255-03U-03A1-6	2	P14494-11	250	300	P14494-11	250	300
ACS255-03U-04A1-6	3	P14494-11	250	300	P14494-11	250	300
ACS255-03U-06A5-6	5	P14494-15	150	300	P14494-16	150	600
ACS255-03U-09A0-6	7.5	P14494-20	75	600	P14494-20	75	600
ACS255-03U-12A0-6	10	P14494-66	60	700	P14494-67	60	1200
ACS255-03U-17A0-6	15	P14494-32	35	820	P14494-33	35	1200
ACS255-03U-22A0-6	20	P14494-33	35	1200	P14494-38	35	1865
		DutyCycle=30sec on/180sec off			DutyCycle=60sec on/180sec off		
Drive type code	HP	Resistor part no.	Ohms	Watts	Resistor part no.	Ohms	Watts
ACS255-03U-02A1-6	1.5	P14494-11	250	300	P14494-11	250	300
ACS255-03U-03A1-6	2	P14494-11	250	300	P14494-12	250	600
ACS255-03U-04A1-6	3	P14494-12	250	600	P14494-12	250	600
ACS255-03U-06A5-6	5	P14494-16	150	600	P14494-18	150	1200
ACS255-03U-09A0-6	7.5	P14494-21	75	1000	P14494-22	80	1600
ACS255-03U-12A0-6	10	P14494-67	60	1200	P14494-69	60	2000
ACS255-03U-17A0-6	15	P14494-38	35	1865	P14494-36	35	3600
ACS255-03U-22A0-6	20	P14494-35	35	2500	P14494-45	21	4400

Notes: To determine resistor type, dimensions and weights refer to Resistor Technical Data Tables

Resistor technical data

Part number	Ohms	Watts	Encl	Dimensions W x D x H (inches)	Weight (lbs)
P14494-11	255	300	GCE1	12W x 5D x 5H	7
P14494-12	255	600	GCE2	12W x 7D x 5H	10
P14494-13	200	300	GCE1	12W x 5D x 5H	7
P14494-14	200	600	GCE2	12W x 7D x 5H	10
P14494-15	150	300	GCE1	12W x 5D x 5H	7
P14494-16	150	600	GCE2	12W x 7D x 5H	10
P14494-18	150	1200	GCE4	12W x 13D x 5H	16
P14494-19	75	300	GCE1	12W x 5D x 5H	7
P14494-20	75	600	GCE2	12W x 7D x 5H	10
P14494-21	75	1000	GCE3	12W x 10D x 5H	13
P14494-25	45	800	GCE2	12W x 7D x 5H	10
P14494-26	45	1260	GCE3	12W x 10D x 5H	13
P14494-27	45	1920	GCE5	12W x 16D x 5H	18
P14494-31	35	300	GCE1	12W x 5D x 5H	7
P14494-32	35	820	GCE2	12W x 7D x 5H	10
P14494-34	35	1600	GCE4	12W x 13D x 5H	16
P14494-CR-02	200	100	CR100	6W x 1.5D x 0.75H	1
P14494-CR-03	150	100	CR100	6W x 1.5D x 0.75H	1
P14494-CR-06	50	100	CR100	6W x 1.5D x 0.75H	1
P14494-CR-08	255	150	CR150	9W x 1.5D x 0.75H	1
P14494-CR-11	100	150	CR150	9W x 1.5D x 0.75H	1
P14494-CR-12	50	150	CR150	9W x 1.5D x 0.75H	1
P14494-CR-13	255	200	CR200	6W x 3D x 1.5H	2
P14494-CR-15	150	200	CR200	6W x 3D x 1.5H	2
P14494-CR-18	50	200	CR200	6W x 3D x 1.5H	2
P14494-CR-19	255	300	CR300	9W x 3D x 1.5H	3
P14494-CR-21	150	300	CR300	9W x 3D x 1.5H	3
P14494-CR-22	100	300	CR300	9W x 3D x 1.5H	3
P14494-CR-24	50	300	CR300	9W x 3D x 1.5H	3
P14494-CR-26	40	300	CR300	9W x 3D x 1.5H	3
P14494-CR-27	255	400	CR400	12W x 3D x 1.5H	4
P14494-CR-29	150	400	CR400	12W x 3D x 1.5H	4
P14494-CR-30	100	400	CR400	12W x 3D x 1.5H	4
P14494-CR-31	75	400	CR400	12W x 3D x 1.5H	4
P14494-CR-32	50	400	CR400	12W x 3D x 1.5H	4
P14494-CR-34	40	400	CR400	12W x 3D x 1.5H	4
ABB-48431-052	80	800	GCE2	12W x 7D x 5H	10
P14494-63	80	1050	GCE3	12W x 10D x 5H	13
P14494-62	63	800	GCE2	12W x 7D x 5H	10
ABB-48431-140	63	1200	GCE3	12W x 10D x 5H	13
ABB-41163	35	900	GCE3	12W x 10D x 5H	13
P14494-34	35	1600	GCE4	12W x 13D x 5H	16
P14494-33	35	1200	GCE3	12W x 10D x 5H	13
ABB-44534	40	2010	GCE5	12W x 16D x 5H	18

Type CR case resistor

Information and dimensions

Overview

Powerohm's Type CR resistors are manufactured with quality components for superior performance and increased life expectancy. Our case resistors feature a nickel-chromium wire helically wound, then placed inside a ceramic fixture and inserted into a corrosion resistant aluminum case. Each coil end is terminated to high temperature wire leads

and encapsulated with a ceramic potting material. The result is a resistor element electrically isolated, but thermally bound to the outer case to allow the element heat to transfer to the metallic case and efficiently cool. The units are supplied with 18" wire leads, and the case is machined to include two mounting holes for easy installation.

Electrical Ratings & Dimensions of Standard Size Case Resistors

Wattage	Dimension (in)				
	A	B	C	D	E
100	6	1-1/2	3/4	5-1/2	3/4
150	9	1-1/2	3/4	8-1/2	3/4
200	6	3	1-1/2	5-1/2	1-1/2
300	9	3	1-1/2	8-1/2	1-1/2
400	12	3	1-1/2	11-1/2	1-1/2

TOP VIEW

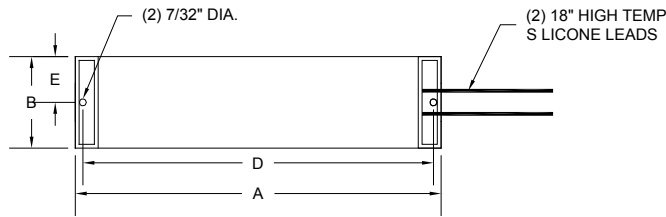

FRONT VIEW

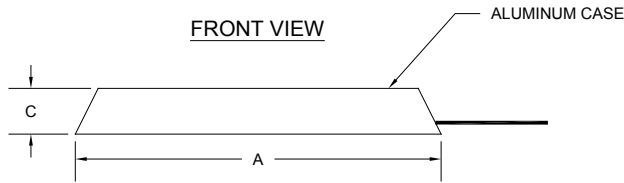

Type GCE resistor

Information and dimensions

Overview

The type GCE enclosures are heavy gage screened enclosures featuring a solid bottom and a built-in wiring compartment separated from the resistor assembly. The resistors are factory wired to a terminal block mounted in this compartment using high temperature Teflon or silicone wire. The terminal compartment also houses a normally closed thermal switch used for detecting resistor temperature overloads. During installation, standard 90°C rated wire is routed into the compartment through the removable 1/2 inch conduit knockouts and connected to the factory wired terminal block.

Our standard unit includes a screened cover which is CNC punched to obtain maximum cooling and professional aesthetics. Mounting holes are located inside the enclosure and can be easily

accessed by removing the cover. Resistor coils are interconnected using stainless steel bus bars, producing a corrosion resistant current path to withstand nearly any harsh industrial environment. The standard finish is galvanized, but an optional powder coated, aluminum or stainless steel finish is available upon request. As shown in the table below, the size of the enclosure will vary depending on the number of resistor coils required for your application. Units are available with louvered covers; add "-W" to the part number and note that the 'A' and 'B' dimensions will increase by an inch. Please do not hesitate to call the factory if you need assistance.

GCE Enclosure Dimensions and Coil Options

Part No.	Max. No. WR Coils	Max. No. SXR, VR or ER	Dimensions (in)				
			A	B	C	D	E
GCE1	1	(1) Size 2	12	5	5	10-1/2	---
GCE2	2	(2) Size 2	12	7	5	10-1/2	4-1/2
GCE3	3	(3) Size 2	12	10	5	10-1/2	7-1/2
GCE4	4	(4) Size 2	12	13	5	10-1/2	10-1/2
GCE5	5	(5) Size 2	12	16	5	10-1/2	13-1/2

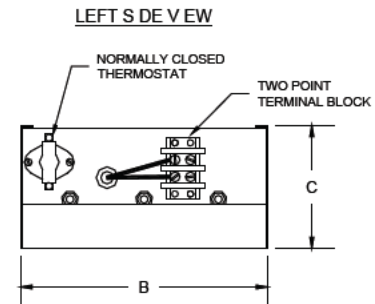
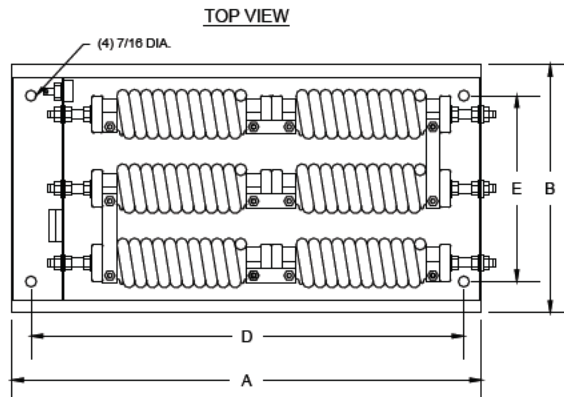

Installation instructions for PowerOhm brake resistors

Construction: Powerohm braking resistors consists of smooth-wound, wire-wound or edge-wound type resistor coils mounted in ventilated enclosures. All current carrying components used to manufacture our resistor coils including the elements and terminals are stainless steel for maximum corrosion resistance. Standard enclosures will be mill galvanized with terminals factory wired to a terminal block and normally closed thermal switch. Braking resistors are available with a variety of options such as special enclosure finishes and outdoor ratings.

Inspection: Upon receipt of your Powerohm Braking Resistor, be sure to inspect the unit carefully for any shipping damage. After unpacking, check the unit for loose, broken, bent or otherwise damaged parts due to shipping. Report any shipping damage immediately to the freight carrier. Be sure to verify that the part number and ratings listed on the nameplate conform to the order specification. The ohm rating listed on the nameplate is critical (too low of an ohm value may cause damage to the drive).

Installation:

IMPORTANT: The National Electric Code (NEC) and local regulations govern the installation and wiring of electrical equipment such as braking resistors. DC power wiring, AC power wiring, control wiring and conduit must be installed in accordance with these codes.

Powerohm braking assemblies cool by natural convection causing hot air to rise vertically from the enclosure. Braking resistors should be mounted in a well ventilated location free of any combustible materials or equipment affected by heat. Units should be installed with at least 24 inches of free space above the enclosure top and 6 inches of free space surrounding the enclosure sides. If necessary, units can be mounted on spacers or channels to limit heat from conducting from the resistor enclosure to its mounting surface.

Braking resistor enclosures 28 inches or less in width, can be mounted vertically or horizontally. If the unit is mounted vertically, it is important that the resistor coils remain in a horizontal position. Also, if a thermal switch is included with the unit, position the equipment so the switch remains near the top of the enclosure. See below for vertical mounting details.

Smaller 28 inch wide enclosures have convenient conduit knockouts for easy connection. Remove the proper knockout after determining a suitable entry point. Larger units may require field punching for conduit entry. It is preferable to route conduit near the bottom of the resistor enclosure. After attaching conduit, pull wiring into the enclosure for connection to resistor. If connecting directly to the terminals on the resistor elements, it is necessary to use high temperature silicon or Teflon wire rated 200°C. Try to route wiring along the bottom of the enclosure and avoid running the wiring across the top or near the resistor elements. Units are supplied with either #10, 3/8 or 1/2 inch terminal hardware. If you choose to use the factory installed terminal block, then you may connect to it using standard 90°C rated wire. Be sure to properly ground the resistor enclosure to prevent electrical shock. A normally closed thermal switch is included with the unit, featuring ¼ inch quick connect terminals.

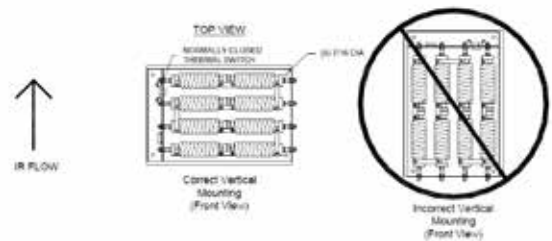

After installing and wiring to your Powerohm Braking Resistor, return the ventilated cover to its proper position. Securely tighten cover hardware (do not exceed 20 inch-pounds of torque).

Installation instructions for PowerOhm brake resistors

Maintenance: Periodically check the unit for loose connections and an accumulation of dust or dirt on the inside and outside of the resistor enclosure. Be sure to allow the unit to cool before servicing (contact may result in burn injury). Remove all power before servicing unit to avoid electrical shock. Allow at least one minute after input power has been removed for the bus voltage to discharge. Electric shock can cause injury or death. Resistor elements should not glow red under normal operating conditions. If the resistor elements glow red you may need a higher rated braking resistor.

Technical Support: If you have any questions about your braking resistor, contact Powerohm for assistance at (800) 838-4694.

Input reactors

Applications:

Line side power conditioning for AC motor controls to prevent unwanted harmonics and nuisance drive trips as well as to prevent excess current during line disturbances that can damage power semi-conductors. There should be a minimum impedance associated with the drive using either AC or DC magnetics. In many applications, this impedance can come from a supply transformer, or if long enough, the supply cable themselves. In most cases, however, the use of an additional input reactor is recommended.

If any of the following conditions exist use of at least a 3% line reactor is recommended:

- Installation has voltage spikes in excess of 6000V peak or lightning strikes.
- Installation has switched power factor correction capacitors.
- Installation has power interruptions or voltage sags in excess of 200Vac.
- When the distribution system kVA is more than 10 times larger than the drive kVA .

Features:

Open, UL Type 1 and UL Type 3R construction with connection terminals. 3% and 5% impedance rating at rated current.



Input reactors

High impedance

Single Phase 200-240V applications

Drive Part No. ACS255-01U-	HP P _N	Drive Input Current @ 200V	Drive Input current @ 200V with 3% choke	Drive Output Current I _{2N}	Reactor Max Current Rating (A)	KDR UR 5%, Open, Not UL	KDR 5%, UL Listed, Open			
						Part Number	Part Number	Watts	Dimensions (HxWxD)	Weight
02A3-2	0.5	3.7	2.9	2.3	3.0	KDRA54H	KDRULA54H	14	4.00x4.18x3.75	4
04A3-2	1	7.5	6.6	4.3	7.5	KDRA27H	KDRULA27H	30.6	4.00x4.18x3.75	4
06A1-2	1.5	11	9.7	6.1	11.0	KDRA28H	KDRULA28H	43.1	4x4.18x3.75	4
07A0-2	2	12.9	11.4	7	17.0	KDRB25H	KDRULB25H	53.1	5x6x4	8
10A5-2	3	19.2	17	10.5	17.0	KDRB25H	KDRULB25H	53.1	5x6x4	8
15A3-2	5	29.2	25.9	15.3	26.0	KDRB26H	KDRULB26H	66.5	5x6x4	8

Three Phase 200-240V applications

Drive Part No. ACS255-03U-	HP P _N	Drive Input Current @ 200V	Drive Input current @ 200V with 3% choke	Drive Output Current I _{2N}	Reactor Max Current Rating (A)	KDR UR 5%, Open, Not UL	KDR 5%, UL Listed, Open			
						Part Number	Part Number	Watts	Dimensions (HxWxD)	Weight
02A3-2	0.5	3.4	2.8	2.3	3.0	KDRA54H	KDRULA54H	14	4.00x4.18x3.75	4
04A3-2	1	5.6	4.4	4.3	5.0	KDRA53H	KDRULA53H	16.8	4.00x4.18x3.75	4
06A1-2	1.5	8.1	6.3	6.1	7.5	KDRA27H	KDRULA27H	30.6	4.00x4.18x3.75	4
07A0-2	2	8.9	7	7	7.5	KDRA27H	KDRULA27H	30.6	4.00x4.18x3.75	4
10A5-2	3	12.1	9.9	10.5	11.0	KDRA28H	KDRULA28H	43.1	4x4.18x3.75	4
18A0-2	5	20.9	17.4	18	26.0	KDRB26H	KDRULB26H	66.5	5x6x4	8

Three Phase 380-480V applications

Drive Part No. ACS255-03U-	HP P _N	Drive Input Current @ 480V	Drive Input current @ 480V with 3% choke	Drive Output Current I _{2N}	Reactor Max Current Rating (A)	KDR UR 5%, Open, Not UL	KDR 5%, UL Listed, Open			
						Part Number	Part Number	Watts	Dimensions (HxWxD)	Weight
01A2-4	0.5	1.9	1.5	1.2	1.5	KDRA6H	KDRULA6H	9	4.00x4.18x3.75	4
02A2-4	1	3.5	2.7	2.2	3.0	KDRA9H	KDRULA9H	23	4.00x4.18x3.75	4
03A3-4	1.5	4.6	3.3	3.3	4.0	KDRA1H	KDRULA1H	33	4.00x4.18x3.75	4
04A1-4	2	5.6	4.5	4.1	6.0	KDRA2H	KDRULA2H	38	4.00x4.18x3.75	4
05A8-4	3	7.5	5.5	5.8	6.0	KDRA2H	KDRULA2H	38	4.00x4.18x3.75	4
09A5-4	5	11.5	9.2	9.5	12.0	KDRA4H	KDRULA4H	77	4x4.18x3.75	5
14A0-4	7.5	17.2	14.5	14	27.0	KDRB2H	KDRULB2H	133	5.0x6.0x4.0	7
18A0-4	10	21.2	17.2	18	27.0	KDRB2H	KDRULB2H	133	5.0x6.0x4.0	7

Three Phase 550-600V applications

Drive Part No. ACS255-03U-	HP P _N	Drive Input Current @ 600V	Drive Input current @ 600V with 3% choke	Drive Output Current I _{2N}	Reactor Max Current Rating (A)	KDR UR 5%, Open, Not UL	KDR 5%, UL Listed, Open			
						Part Number	Part Number	Watts	Dimensions (HxWxD)	Weight
02A1-6	1	2.7	2.1	2.1	2.1	KDRA52H	KDRULA52H	13.3	4.00x4.18x3.75	4
03A1-6	2	3.7	3.1	3.1	3.2	KDRA43H	KDRULA43H	23.6	4.00x4.18x3.75	4
04A1-6	3	4.8	4.1	4.1	5.0	KDRA44H	KDRULA44H	34.5	4.00x4.18x3.75	4
06A5-6	5	7.1	6.5	6.5	7.5	KDRA45H	KDRULA45H	47.8	4.00x4.18x3.75	4
09A0-6	7.5	10.2	9	9	10.0	KDRB42H	KDRULB42H	61.1	5x6x4	8
12A0-6	10	14.4	12	12	18.5	KDRB44H	KDRULB44H	73	5x6x4	8
17A0-6	15	19.1	17	17	18.5	KDRB44H	KDRULB44H	73	5x6x4	8
22A0-6	20	23.6	22	22	23.0	KDRD41H	KDRULD41H	105.6	5.75x7.20x4.25	12

Input reactors

High impedance

KDR UR 5%, NEMA 1, Not UL		KDR 5%, UL Type 1 Enclosure			KDR 5%, UL Type 3R Enclosure			
Part Number	Part Number	Watts	Dimensions (HxWxD)	Weight	Part Number	Watts	Dimensions (HxWxD)	Weight
KDRA54HC1	KDRULA54HE01	14	12.25x12.5x6.75	14.5	KDRULA54HE3R	14	11.5x10x12	19
KDRA27HC1	KDRULA27HE01	30.6	12.25x12.5x6.75	14.5	KDRULA27HE3R	30.6	11.5x10x12	19
KDRA28HC1	KDRULA28HE01	43.1	12.25x12.5x6.75	14.5	KDRULA28HE3R	43.1	11.5x10x12	19
KDRB25HC1	KDRULB25HE01	53.1	12.25x12.5x6.75	18.5	KDRULB25HE3R	53.1	11.5x10x12	23
KDRB25HC1	KDRULB25HE01	53.1	12.25x12.5x6.75	18.5	KDRULB25HE3R	53.1	11.5x10x12	23
KDRB26HC1	KDRULB26HE01	66.5	12.25x12.5x6.75	18.5	KDRULB26HE3R	66.5	11.5x10x12	23

KDR UR 5%, NEMA 1, Not UL		KDR 5%, UL Type 1 Enclosure			KDR 5%, UL Type 3R Enclosure			
Part Number	Part Number	Watts	Dimensions (HxWxD)	Weight	Part Number	Watts	Dimensions (HxWxD)	Weight
KDRA54HC1	KDRULA54HE01	14	12.25x12.5x6.75	14.5	KDRULA54HE3R	14	11.5x10x12	19
KDRA53HC1	KDRULA53HE01	16.8	12.25x12.5x6.75	14.5	KDRULA53HE3R	16.8	11.5x10x12	19
KDRA27HC1	KDRULA27HE01	30.6	12.25x12.5x6.75	14.5	KDRULA27HE3R	30.6	11.5x10x12	19
KDRA27HC1	KDRULA27HE01	30.6	12.25x12.5x6.75	14.5	KDRULA27HE3R	30.6	11.5x10x12	19
KDRA28HC1	KDRULA28HE01	43.1	12.25x12.5x6.75	14.5	KDRULA28HE3R	43.1	11.5x10x12	19
KDRB26HC1	KDRULB26HE01	66.5	12.25x12.5x6.75	18.5	KDRULB26HE3R	66.5	11.5x10x12	23

KDR UR 5%, NEMA 1, Not UL		KDR 5%, UL Type 1 Enclosure			KDR 5%, UL Type 3R Enclosure			
Part Number	Part Number	Watts	Dimensions (HxWxD)	Weight	Part Number	Watts	Dimensions (HxWxD)	Weight
KDRA6HC1	KDRULA6HE01	9	12.25x12.5x6.75	14.5	KDRULA6HE3R	9	11.5x10x12	19
KDRA9HC1	KDRULA9HE01	23	12.25x12.5x6.75	14.5	KDRULA9HE3R	23	11.5x10x12	19
KDRA1HC1	KDRULA1HE01	33	12.25x12.5x6.75	14.5	KDRULA1HE3R	33	11.5x10x12	19
KDRA2HC1	KDRULA2HE01	38	12.25x12.5x6.75	14.5	KDRULA2HE3R	38	11.5x10x12	19
KDRA2HC1	KDRULA2HE01	38	12.25x12.5x6.75	14.5	KDRULA2HE3R	38	11.5x10x12	19
KDRA4HC1	KDRULA4HE01	77	12.25x12.5x6.75	15.5	KDRULA4HE3R	77	11.5x10x12	20
KDRB2HC1	KDRULB2HE01	133	12.25x12.5x6.75	17.5	KDRULB2HE3R	133	11.5x10x12	22
KDRB2HC1	KDRULB2HE01	133	12.25x12.5x6.75	17.5	KDRULB2HE3R	133	11.5x10x12	22

KDR UR 5%, NEMA 1, Not UL		KDR 5%, UL Type 1 Enclosure			KDR 5%, UL Type 3R Enclosure			
Part Number	Part Number	Watts	Dimensions (HxWxD)	Weight	Part Number	Watts	Dimensions (HxWxD)	Weight
KDRA52HC1	KDRULA52HE01	13.3	12.25x12.5x6.75	14.5	KDRULA52HE3R	13.3	11.5x10x12	19
KDRA43HC1	KDRULA43HE01	23.6	12.25x12.5x6.75	14.5	KDRULA43HE3R	23.6	11.5x10x12	19
KDRA44HC1	KDRULA44HE01	34.5	12.25x12.5x6.75	14.5	KDRULA44HE3R	34.5	11.5x10x12	19
KDRA45HC1	KDRULA45HE01	47.8	12.25x12.5x6.75	14.5	KDRULA45HE3R	47.8	11.5x10x12	19
KDRB42HC2	KDRULB42HE01	61	12.25x12.5x6.75	18.5	KDRULB42HE3R	61	11.5x10x12	23
KDRB44HC2	KDRULB44HE01	73	12.25x12.5x6.75	18.5	KDRULB44HE3R	73	11.5x10x12	23
KDRB44HC2	KDRULB44HE01	73	12.25x12.5x6.75	18.5	KDRULB44HE3R	73	11.5x10x12	23
KDRD41HC2	KDRULD41HE01	105.6	12.25x12.5x6.75	22.5	KDRULD41HE3R	105.6	11.5x10x12	27

Input reactors

Low impedance

Single Phase 200-240V applications (connect to terminals A and C)

Drive Part No. ACS255-01U-	HP P _N	Drive Input Current @ 200V	Drive Input current @ 200V with 3% choke	Drive Output Current I _{2N}	Reactor Max Current Rating (A)	KDR UR 3%, Open, Not UL	KDR 3%, UL Listed, Open			
						Part Number	Part Number	Watts	Dimensions (HxWxD)	Weight
02A3-2	0.5	3.7	2.9	2.3	3	KDRA54L	KDRULA54L	7	4x4.18x3.75	4
04A3-2	1	7.5	6.6	4.3	8	KDRA26L	KDRULA26L	18	4x4.18x3.75	4
06A1-2	1.5	11	9.7	6.1	10	KDRA27L	KDRULA27L	21	4x4.18x3.75	4
07A0-2	2	12.9	11.4	7	12	KDRA28L	KDRULA28L	29	4x4.18x3.75	4
10A5-2	3	19.2	17	10.5	19	KDRB22L	KDRULB22L	38	5 x 6 x 4	8
15A3-2	5	29.2	25.9	15.3	34	KDRD25L	KDRULD25L	64	5.75x7.2x4.25	12

Three Phase 200-240V applications

Drive Part No. ACS255-03U-	HP P _N	Drive Input Current @ 200V	Drive Input current @ 200V with 3% choke	Drive Output Current I _{2N}	Reactor Max Current Rating (A)	KDR UR 3%, Open, Not UL	KDR 3%, UL Listed, Open			
						Part Number	Part Number	Watts	Dimensions (HxWxD)	Weight
02A3-2	0.5	3.4	2.8	2.3	3	KDRA54L	KDRULA54L	7	4x4.18x3.75	4
04A3-2	1	5.6	4.4	4.3	5.50	KDRA25L	KDRULA25L	11	4x4.18x3.75	4
06A1-2	1.5	8.1	6.3	6.1	8	KDRA26L	KDRULA26L	18	4x4.18x3.75	4
07A0-2	2	8.9	7	7	8	KDRA26L	KDRULA26L	18	4x4.18x3.75	4
10A5-2	3	12.1	9.9	10.5	10	KDRA27L	KDRULA27L	21	4x4.18x3.75	4
18A0-2	5	20.9	17.4	18	19	KDRB22L	KDRULB22L	38	5 x 6 x 4	8

Three Phase 380-480V applications

Drive Part No. ACS255-03U-	HP P _N	Drive Input Current @ 480V	Drive Input current @ 480V with 3% choke	Drive Output Current I _{2N}	Reactor Max Current Rating (A)	KDR UR 3%, Open, Not UL	KDR 3%, UL Listed, Open			
						Part Number	Part Number	Watts	Dimensions (HxWxD)	Weight
01A2-4	0.5	1.9	1.5	1.2	1.50	KDRA6L	KDRULA6L	5.6	4x4.18x3.75	4
02A2-4	1	3.5	2.7	2.2	3	KDRA9L	KDRULA9L	17	4x4.18x3.75	4
03A3-4	1.5	4.6	3.3	3.3	6.40	KDRA1L	KDRULA1L	19	4x4.18x3.75	4
04A1-4	2	5.6	4.5	4.1	6.40	KDRA1L	KDRULA1L	19	4x4.18x3.75	4
05A8-4	3	7.5	5.5	5.8	6.40	KDRA1L	KDRULA1L	19	4x4.18x3.75	4
09A5-4	5	11.5	9.2	9.5	9.60	KDRA3L	KDRULA3L	49	4x4.18x3.75	4
14A0-4	7.5	17.2	14.5	14	30	KDRB2L	KDRULB2L	65	5 x 6 x 4	8
18A0-4	10	21.2	17.2	18	30	KDRB2L	KDRULB2L	65	5 x 6 x 4	8

Three Phase 550-600V applications

Drive Part No. ACS255-03U-	HP P _N	Drive Input Current @ 600V	Drive Input current @ 600V with 3% choke	Drive Output Current I _{2N}	Reactor Max Current Rating (A)	KDR UR 3%, Open, Not UL	KDR 3%, UL Listed, Open			
						Part Number	Part Number	Watts	Dimensions (HxWxD)	Weight
02A1-6	1	2.7	2.1	2.1	2.10	KDRA50L	KDRULA50L	12	4x4.18x3.75	4
03A1-6	2	3.7	3.1	3.1	3.30	KDRA46L	KDRULA46L	22	4x4.18x3.75	4
04A1-6	3	4.8	4.1	4.1	5	KDRA52L	KDRULA52L	23.3	4x4.18x3.75	4
06A5-6	5	7.1	6.5	6.5	7	KDRA47L	KDRULA47L	34.7	4x4.18x3.75	4
09A0-6	7.5	10.2	9	9	10.40	KDRA48L	KDRULA48L	42.9	4x4.18x3.75	4
12A0-6	10	14.4	12	12	19.50	KDRB45L	KDRULB45L	66.2	4x4.18x3.75	8
17A0-6	15	19.1	17	17	19.50	KDRB45L	KDRULB45L	66.2	5x6x4	8
22A0-6	20	23.6	22	22	24	KDRB44L	KDRULB44L	71.2	5x6x4	8

Input reactors

Low impedance

KDR UR 3%, NEMA 1, Not UL		KDR 3%, UL Type 1 Enclosure			KDR 3%, UL Type 3R Enclosure			
Part Number	Part Number	Watts	Dimensions (HxWxD)	Weight	Part Number	Watts	Dimensions (HxWxD)	Weight
KDRA54LC1	KDRULA54LE01	7	12.25x12.5x6.75	14.5	KDRULA54L	7	11.5x10x12	19
KDRA26LC1	KDRULA26LE01	18	12.25x12.5x6.75	14.5	KDRULA26LE3R	18	11.5x10x12	19
KDRA27LC1	KDRULA27LE01	21	12.25x12.5x6.75	14.5	KDRULA27LE3R	21	11.5x10x12	19
KDRA28LC1	KDRULA28LE01	29	12.25x12.5x6.75	14.5	KDRULA28LE3R	29	11.5x10x12	19
KDRB22LC1	KDRULB22LE01	38	12.25x12.5x6.75	18.5	KDRULB22LE3R	38	11.5x10x12	23
KDRD25LC2	KDRULD25LE01	64	12.25x12.5x6.75	22.5	KDRULD25LE3R	64	11.5x10x12	27

KDR UR 3%, NEMA 1, Not UL		KDR 3%, UL Type 1 Enclosure			KDR 3%, UL Type 3R Enclosure			
Part Number	Part Number	Watts	Dimensions (HxWxD)	Weight	Part Number	Watts	Dimensions (HxWxD)	Weight
KDRA54LC1	KDRULA54LE01	7	12.25x12.5x6.75	14.5	KDRULA54L	7	11.5x10x12	19
KDRA25LC1	KDRULA25LE01	11	12.25x12.5x6.75	14.5	KDRULA25LE3R	11	11.5x10x12	19
KDRA26LC1	KDRULA26LE01	18	12.25x12.5x6.75	14.5	KDRULA26LE3R	18	11.5x10x12	19
KDRA26LC1	KDRULA26LE01	18	12.25x12.5x6.75	14.5	KDRULA26LE3R	18	11.5x10x12	19
KDRA27LC1	KDRULA27LE01	21	12.25x12.5x6.75	14.5	KDRULA27LE3R	21	11.5x10x12	19
KDRB22LC1	KDRULB22LE01	38	12.25x12.5x6.75	18.5	KDRULB22LE3R	38	11.5x10x12	23

KDR UR 3%, NEMA 1, Not UL		KDR 3%, UL Type 1 Enclosure			KDR 3%, UL Type 3R Enclosure			
Part Number	Part Number	Watts	Dimensions (HxWxD)	Weight	Part Number	Watts	Dimensions (HxWxD)	Weight
KDRA6LC1	KDRULA6L	5.6	12.25x12.5x6.75	14.5	KDRULA6L	5.6	11.5x10x12	19
KDRA9LC1	KDRULA9LE01	17	12.25x12.5x6.75	14.5	KDRULA9LE3R	17	11.5x10x12	19
KDRA1LC1	KDRULA1LE01	19	12.25x12.5x6.75	14.5	KDRULA1LE3R	19	11.5x10x12	19
KDRA1LC1	KDRULA1LE01	19	12.25x12.5x6.75	14.5	KDRULA1LE3R	19	11.5x10x12	19
KDRA1LC1	KDRULA1LE01	19	12.25x12.5x6.75	14.5	KDRULA1LE3R	19	11.5x10x12	19
KDRA3LC1	KDRULA3LE01	49	12.25x12.5x6.75	14.5	KDRULA3LE3R	49	11.5x10x12	19
KDRB2LC1	KDRULB2LE01	65	12.25x12.5x6.75	18.5	KDRULB2LE3R	65	11.5x10x12	23
KDRB2LC1	KDRULB2LE01	65	12.25x12.5x6.75	18.5	KDRULB2LE3R	65	11.5x10x12	23

KDR UR 3%, NEMA 1, Not UL		KDR 3%, UL Type 1 Enclosure			KDR 3%, UL Type 3R Enclosure			
Part Number	Part Number	Watts	Dimensions (HxWxD)	Weight	Part Number	Watts	Dimensions (HxWxD)	Weight
KDRA50LC1	KDRULA50LE01	12	12.25x12.5x6.75	14.5	KDRULA50LE3R	12	11.5x10x12	19
KDRA46LC1	KDRULA46LE01	22	12.25x12.5x6.75	14.5	KDRULA46LE3R	22	11.5x10x12	19
KDRA52LC1	KDRULA52LE01	23.3	12.25x12.5x6.75	14.5	KDRULA52LE3R	23.3	11.5x10x12	19
KDRA47LC1	KDRULA47LE01	34.7	12.25x12.5x6.75	14.5	KDRULA47LE3R	34.7	11.5x10x12	19
KDRA48LC1	KDRULA48LE01	42.9	12.25x12.5x6.75	14.5	KDRULA48LE3R	42.9	11.5x10x12	19
KDRB45LC1	KDRULB45LE01	66.2	12.25x12.5x6.75	18.5	KDRULB45LE3R	66.2	11.5x10x12	23
KDRB45LC1	KDRULB45LE01	66.2	12.25x12.5x6.75	18.5	KDRULB45LE3R	66.2	11.5x10x12	23
KDRB44LC1	KDRULB44LE01	71.2	12.25x12.5x6.75	18.5	KDRULB44LE3R	71.2	11.5x10x12	23

dv/dt output filters

Applications:

V1k Output Filters provide motor protection by limiting voltage spikes to 1,000 volts, or below, for long motor cable applications.

Greatly extends the life of the motor and cable for all applications up to 1000 feet.

For multi-motor applications note that motor lead length is cumulative and the 1000 foot limit still applies.

30% reduction in common mode current enough,

Features:

UL Open, UL Type 1 and UL Type 3R construction with connection terminals.

Note:

The drives internal EMC filter must remain disconnected when using these filters.
When applying these output filters the drive output frequency is limited to 60Hz.



Single Phase 200-240V applications

Drive Part No.	HP	Drive Output Current I_{2N}	V1K UL Open			
			Part Number	Watts	Dimensions (HxWxD)	Weight
ACS255-01U-	ND					
02A3-2	0.5	2.3	V1K3A00	75	9.00x5.50x7.25	8
04A3-2	1	4.3	V1K6A00	80	9.00x5.50x7.25	8
06A1-2	1.5	6.1	V1K8A00	90	9.00x5.50x7.25	8
07A0-2	2	7	V1K8A00	90	9.00x5.50x7.25	8
10A5-2	3	10.5	V1K12A00	95	9.00x5.50x7.25	8
15A3-2	5	15.3	V1K16A00	95	9.00x5.50x7.25	8

Three Phase 200-240V applications

Drive Part No.	HP	Drive Output Current I_{2N}	V1KULOpen			
			PartNumber	Watts	Dimensions (HxWxD)	Weight
ACS255-03U-	ND					
02A3-2	0.5	2.3	V1K3A00	75	9.00x5.50x7.25	8
04A3-2	1	4.3	V1K6A00	80	9.00x5.50x7.25	8
06A1-2	1.5	6.1	V1K8A00	90	9.00x5.50x7.25	8
07A0-2	2	7	V1K8A00	90	9.00x5.50x7.25	8
10A5-2	3	10.5	V1K12A00	95	9.00x5.50x7.25	8
18A0-2	5	18	V1K21A00	110	9.00x5.50x8.25	12

Three Phase 380-480V applications

Drive Part No.	HP	Drive Output Current I_{2N}	V1K UL Open			
			Part Number	Watts	Dimensions (HxWxD)	Weight
ACS255-03U-	ND					
01A2-4	0.5	1.2	V1K2A00	75	9.00x5.50x7.25	8
02A2-4	1	2.2	V1K3A00	75	9.00x5.50x7.25	8
03A3-4	1.5	3.3	V1K4A00	75	9.00x5.50x7.25	8
04A1-4	2	4.1	V1K6A00	80	9.00x5.50x7.25	8
05A8-4	3	5.8	V1K6A00	80	9.00x5.50x7.25	8
09A5-4	5	9.5	V1K12A00	95	9.00x5.50x7.25	8
14A0-4	7.5	14	V1K16A00	95	9.00x5.50x8.25	12
18A0-4	10	18	V1K18A00	110	9.00x5.50x8.25	12

Three Phase 550-600V applications

Drive Part No.	HP	Drive Output Current I_{2N}	V1K UL Open			
			Part Number	Watts	Dimensions (HxWxD)	Weight
ACS255-03U-	ND					
02A1-6	1	2.1	V1K3A00	75	9.00x5.50x7.25	8
03A1-6	2	3.1	V1K4A00	75	9.00x5.50x7.25	8
04A1-6	3	4.1	V1K6A00	80	9.00x5.50x7.25	8
06A5-6	5	6.5	V1K8A00	90	9.00x5.50x7.25	8
09A0-6	7.5	9	V1K12A00	95	9.00x5.50x7.25	8
12A0-6	10	12	V1K12A00	95	9.00x5.50x7.25	8
17A0-6	15	17	V1K18A00	110	9.00x5.50x8.25	12
22A0-6	20	22	V1K25A00	110	9.00x5.50x8.25	12

V1K UL Type 1 Enclosure				V1k UL Type 3R Enclosure			
Part Number	Watts	Dimensions (HxWxD)	Weight	Part Number	Watts	Dimensions (HxWxD)	Weight
V1K3A01	75	9.00x5.50x10.00	11	V1K3A03	75	11.45x10.00x12.00	25
V1K6A01	80	9.00x5.50x10.00	11	V1K6A03	80	11.45x10.00x12.00	25
V1K8A01	90	9.00x5.50x10.00	11	V1K8A03	90	11.45x10.00x12.00	25
V1K8A01	90	9.00x5.50x10.00	11	V1K8A03	90	11.45x10.00x12.00	25
V1K12A01	95	9.00x5.50x10.00	11	V1K12A03	95	11.45x10.00x12.00	25
V1K16A01	95	9.00x5.50x10.00	15	V1K16A03	95	11.45x10.00x12.00	29

V1KULType1Enclosure				V1kULType3REnclosure			
PartNumber	Watts	Dimensions (HxWxD)	Weight	PartNumber	Watts	Dimensions (HxWxD)	Weight
V1K3A01	75	9.00x5.50x10.00	11	V1K3A03	75	11.45x10.00x12.00	25
V1K6A01	80	9.00x5.50x10.00	11	V1K6A03	80	11.45x10.00x12.00	25
V1K8A01	90	9.00x5.50x10.00	11	V1K8A03	90	11.45x10.00x12.00	25
V1K8A01	90	9.00x5.50x10.00	11	V1K8A03	90	11.45x10.00x12.00	25
V1K12A01	95	9.00x5.50x10.00	11	V1K12A03	95	11.45x10.00x12.00	25
V1K21A01	110	9.00x5.50x10.00	15	V1K21A03	110	11.45x10.00x12.00	29

V1K UL Type 1 Enclosure				V1k UL Type 3R Enclosure			
Part Number	Watts	Dimensions (HxWxD)	Weight	Part Number	Watts	Dimensions (HxWxD)	Weight
V1K2A01	75	9.00x5.50x10.00	11	V1K2A03	11	11.45x10.00x12.00	25
V1K3A01	75	9.00x5.50x10.00	11	V1K3A03	11	11.45x10.00x12.00	25
V1K4A01	75	9.00x5.50x10.00	11	V1K4A03	11	11.45x10.00x12.00	25
V1K6A01	80	9.00x5.50x10.00	11	V1K6A03	11	11.45x10.00x12.00	25
V1K6A01	80	9.00x5.50x10.00	11	V1K6A03	11	11.45x10.00x12.00	25
V1K12A01	95	9.00x5.50x10.00	11	V1K12A03	95	11.45x10.00x12.00	25
V1K16A01	95	9.00x5.50x10.00	15	V1K16A03	15	11.45x10.00x12.00	29
V1K18A01	110	9.00x5.50x10.00	15	V1K18A03	110	11.45x10.00x12.00	25

V1K UL Type 1 Enclosure				V1k UL Type 3R Enclosure			
Part Number	Watts	Dimensions (HxWxD)	Weight	Part Number	Watts	Dimensions (HxWxD)	Weight
V1K3A01	75	9.00x5.50x10.00	11	V1K3A03	11	11.45x10.00x12.00	25
V1K4A01	75	9.00x5.50x10.00	11	V1K4A03	11	11.45x10.00x12.00	25
V1K6A01	80	9.00x5.50x10.00	11	V1K6A03	11	11.45x10.00x12.00	25
V1K8A01	90	9.00x5.50x10.00	11	V1K8A03	11	11.45x10.00x12.00	25
V1K12A01	95	9.00x5.50x10.00	11	V1K12A03	11	11.45x10.00x12.00	25
V1K12A01	95	9.00x5.50x10.00	11	V1K12A03	95	11.45x10.00x12.00	25
V1K18A01	110	9.00x5.50x10.00	15	V1K18A03	110	11.45x10.00x12.00	25
V1K25A01	110	9.00x5.50x10.00	15	V1K25A03	110	11.45x10.00x12.00	29

Expertise at every stage of the value chain

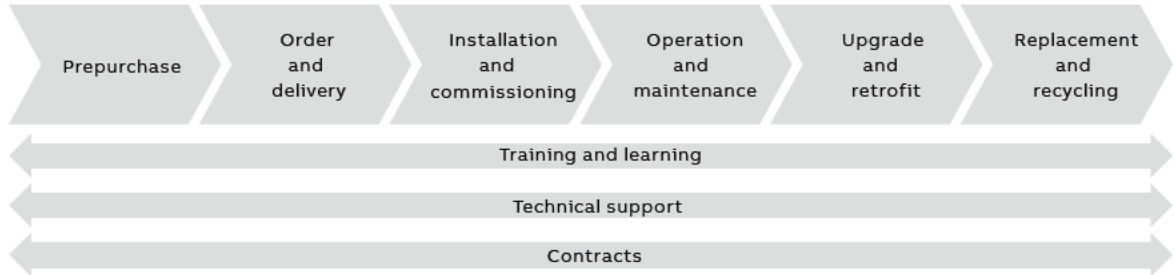

The services offered for ABB low voltage drives span the entire value chain, from the moment a customer makes the first inquiry through to disposal and recycling of the drive. Throughout the value chain, ABB provides training and learning, technical support and contracts. All of this is supported by one of the most extensive global drive sales and service networks.

Pre-purchase

ABB provides a range of services that help guide the customers to the right products for their applications. Examples of services include correct drive selection and dimensioning, energy appraisal, harmonic survey and EMC assessment.

Order and delivery

Orders can be placed through any ABB office or through ABB's channel partners. Orders can be placed and tracked online. ABB's sales and services network offers timely deliveries including express delivery.

Installation and commissioning

While many customers have the resources to undertake installation and commissioning on their own, ABB and its third party channel companies are available to advise or undertake the entire drive installation and commissioning.

Operation and maintenance

Through remote monitoring, ABB can guide the customer through a fast and efficient fault-finding procedure as well as analyze the operation of the drive and the customer's process. From maintenance assessment to preventive maintenance and reconditioning of drives, ABB has all the options covered to keep its customers' processes operational.

Should corrective maintenance of drives be needed, ABB offers on-site and workshop repair, fully backed up by the most extensive spare holding.

Upgrade and retrofit

An existing ABB drive can often be upgraded to the latest software or hardware to improve the performance of the application.

Existing processes can be economically modernized by retrofitting the latest drive technology to mechanical control equipment, such as inlet guide vanes or dampers or older generations of drives.

Instead of replacing an entire drive or drive system, it is often more economical to modernize the old installation by reusing all relevant parts of the original equipment and purchasing new where necessary.

Replacement and recycling

ABB can advise on the best replacement drive while ensuring that the existing drive is disposed in a way that meets all local environmental regulations.

Entire value chain services

The main services available throughout the value chain include:

- Training and learning – ABB offers product and application training in classrooms and on the Internet.
- Technical support – At each stage of the value chain, an ABB expert is available to offer advice to keep the customer's process or plant operational.
- Contracts – Drive care contracts and other types of agreements, from individual services through to complete drive care covering all repairs and even drive replacements, are available.

A lifetime of peak performance

You're in control of every life cycle phase of your drives. At the heart of drive services is a four-phase product life cycle management model. This model defines the services recommended and are available throughout a drive's lifespan.

Now it's easy for you to see the exact service and maintenance available for your drives.

ABB drives life cycle phases explained

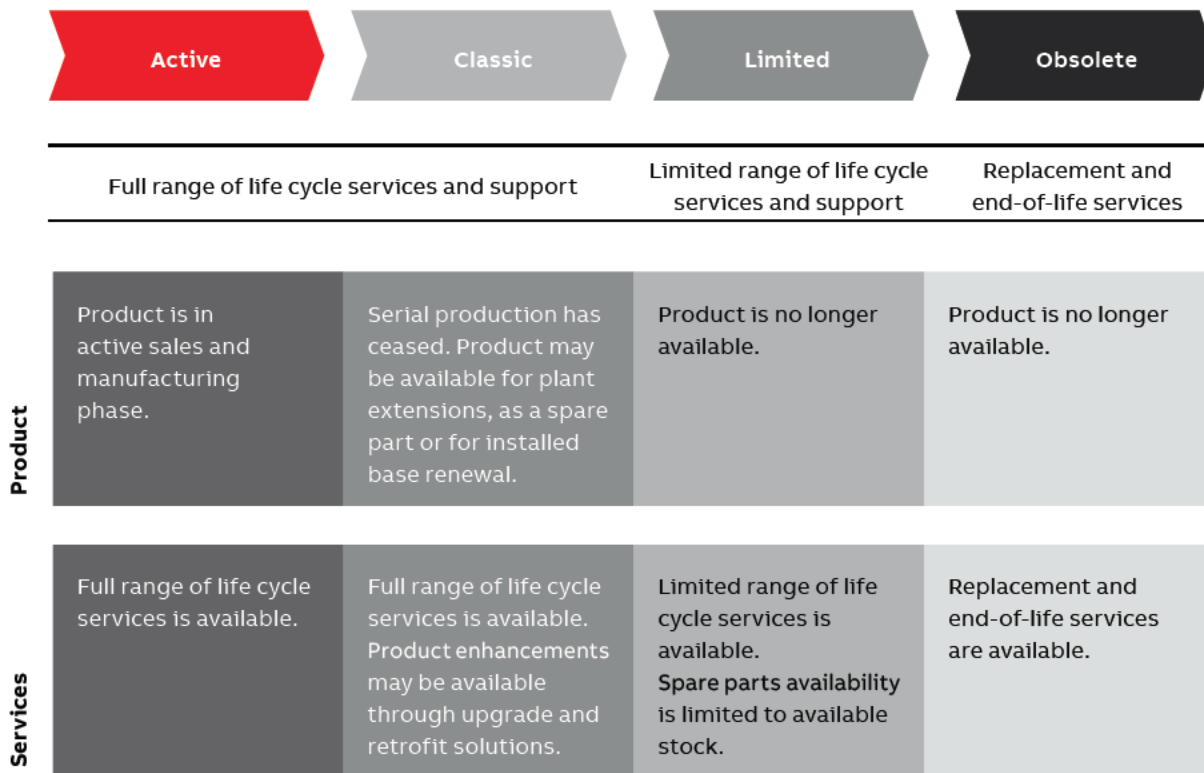

Keeping you informed

We notify you every step of the way using life cycle status statements and announcements.

You benefit from clear information about your drives' status and precise services available. It helps you plan the preferred service actions in advance and make sure that continuous support is always available.

Step 1

Life Cycle Status Announcement

Provides early information about the upcoming life cycle phase change and how it affects the availability of services.

Step 2

Life Cycle Status Statement

Provides information about the drive's current life cycle status, availability of product and services, life cycle plan and recommended actions.

Notes

